



New Hampshire Ball Bearings, Inc.

A Minebea Company

Corrosion Resistant Self-Lubricating Rod End Bearings



ASTRO DIVISION





Corrosion Resistant Self-Lubricating Rod End Bearings

Customers are searching for alternatives to cadmium-plated products and that's why NHBB has become the first industry-qualified source for stainless steel rod ends.

Our stainless steel (CRES), cadmium-free, self-lubricating rod end series is the first to meet the new industry standard, AS81935/6, /7, /8 and /9. This series offers equivalent dimensions and performance to cadmium-plated AS81935/1, /2, /4, and /5 rod ends without the potential risks and regulatory burdens—including European Union environmental regulations—associated with cadmium.

The CRES rod end series is manufactured from corrosion-resistant PH13-8Mo stainless steel. PH13-8Mo combines a high level of corrosion resistance and strength, coupled with superior toughness and transverse mechanical properties. For more corrosion resistance, the ball component can also be made of PH13-8Mo stainless steel.

At NHBB's Astro Division, we manufacture products to our customers' exacting requirements. While we are well-positioned to provide standard CRES self-lubricating rod end bearings at a competitive price, we are dedicated to supporting our customers through the design and production of custom bearings, next-up assemblies, and machined parts. Please contact Astro's sales or engineering teams for assistance with your specific requirements.

NHBB Part Numbering Cross Reference Examples

NEW STANDARD	CURRENT STANDARD
AS81935/6	AS81935/1
ADNEC03	ADNE3J
ADNEC16	ADNE16J
AS81935/7	AS81935/2
ADNC03	ADN3J
ADNC16	ADN16J
AS81935/8	AS81935/4
ADNEC03-382	ADNE3-382
ADNEC16-382	ADNE16-382
AS81935/9	AS81935/5
ADNC03-345	ADN3-345
ADNC16-345	ADN16-345

DESIGNING WITH STAINLESS STEEL:

When specifying stainless steel rod ends, we recommend paying careful attention to the material composition of mating components in order to prevent the potential development of galvanic corrosion resulting from contact of the corrosion resistant steel directly with more active (anodic) materials. If you have any questions about galvanic compatibility, please contact Astro's Product Engineering Group at 603.524.0004.



Corrosion Resistant (CRES) – AS81935/6

Wide—Male Thread

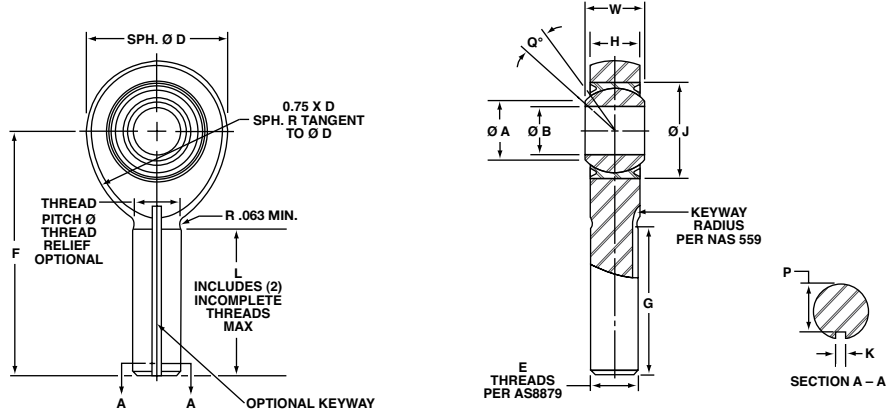

Optional Keyway:

- 03 through -08 sizes per AS81935/3
- 10 through -16 sizes per NAS 559

PART NUMBER	AS DASH NO.	(B) BORE DIA.	(D) SPH. DIA.	(W) BALL WIDTH	(H) BODY WIDTH	(A) SHOULDER DIA.	BALL DIA.	(F) BALL C/L TO END	(E) THREAD SIZE	(L) THREAD LENGTH	(J) HOUSING I.D.	(G) KEYWAY FLAT	(K) KEYWAY WIDTH	(P) KEYWAY	(Q) MIS-ALIGNMENT
M81935/6		+0.000 -0.005	+0.010 -0.010	+0.000 -0.002	+0.005 -0.005	MIN.	REF.	+0.010 -0.010	UNJF-3A	+0.031 -0.031	MAX.	+0.000 -0.020	+0.005 -0.000	+0.000 -0.005	MIN.
ADNEC03	-03	.1900	.806	.437	.337	.300	.531	1.562	.3125-24	.968	.6250	.980	.062	.268	15°
ADNEC04	-04	.2500	.806	.437	.337	.300	.531	1.562	.3125-24	.968	.6250	.980	.062	.268	15°
ADNEC05	-05	.3125	.900	.437	.327	.360	.593	1.875	.3125-24	1.187	.6875	1.270	.062	.268	14°
ADNEC06	-06	.3750	1.025	.500	.416	.470	.687	1.938	.3750-24	1.187	.8125	1.235	.093	.319	8°
ADNEC07	-07	.4375	1.150	.562	.452	.540	.781	2.125	.4375-20	1.281	.9062	1.402	.093	.383	10°
ADNEC08	-08	.5000	1.337	.625	.515	.610	.875	2.438	.5000-20	1.468	1.0000	1.589	.093	.445	9°
ADNEC10	-10	.6250	1.525	.750	.577	.750	1.062	2.625	.6250-18	1.562	1.1875	1.683	.125	.541	12°
ADNEC12	-12	.7500	1.775	.875	.640	.850	1.250	2.875	.7500-16	1.687	1.3750	1.808	.125	.663	13°
ADNEC14	-14	.8750	2.025	.875	.765	1.000	1.375	3.375	.8750-14	2.000	1.6250	2.121	.156	.777	6°
ADNEC16	-16	1.0000	2.775	1.375	1.015	1.270	1.875	4.125	1.2500-12	2.343	2.1250	2.464	.187	1.136	12°

Part Number Coding:

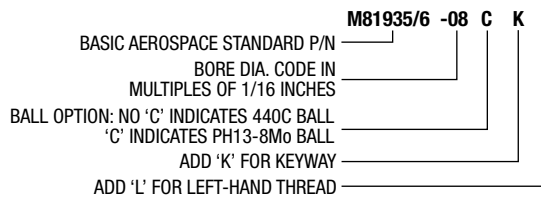
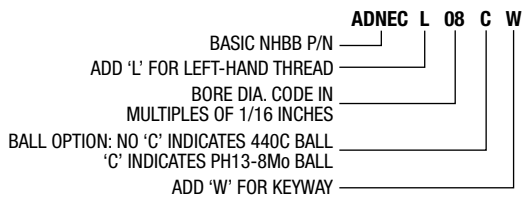

Notes:

- Bearings listed in the tables are approved for procurement to AS81935.
- Operating temperature range per AS81935: -65 to 325 °F. Broader temperature capabilities are achievable.
- All dimensions are in inches unless otherwise specified.

MATERIALS				
Part No.	Ball	Race	Liner	Body
Catalog No.	CRES 440C◆ AMS 5630 55-62 HRC	CRES 17-4PH AMS 5643 28-37 HRC	PTFE/Fabric Bonded to Race I.D. No Lub. Required	PH13-8Mo AMS 5629 40-44 HRC
◆Optional ball material:				
Catalog No. + C*	PH13-8Mo AMS 5629 43 HRC minimum hardness			

*See part number coding above.

PERFORMANCE PROPERTIES – WIDE						
M81935/6	AS Dash No.	No Load Rotational Breakaway Torque	Ultimate Static Radial Load	Axial Static Proof Load	Fatigue Load	Approx. Weight
		In-lbs.	lbs.	lbs.	lbs.	lbs.
ADNEC03	-03	.5-6	2,360	1,000	1,470*	.072
ADNEC04	-04	.5-6	4,860	1,000	2,380	.072
ADNEC05	-05	1-15	7,180	1,100	2,770●	.087
ADNEC06	-06	1-15	8,550	1,660	3,570	.136
ADNEC07	-07	1-15	12,000	1,850	4,800	.183
ADNEC08	-08	1-15	19,500	2,040	7,680●	.278
ADNEC10	-10	1-15	21,900	2,430	9,180	.424
ADNEC12	-12	1-15	29,300	2,810	11,600	.639
ADNEC14	-14	1-24	34,500	3,320	13,100	.963
ADNEC16	-16	1-24	80,300	4,340	30,400	2.546

*Based on bolt bending fatigue strength 180,000 psi.

● Shank limitation



Corrosion Resistant (CRES) – AS81935/7

Wide—Female Thread

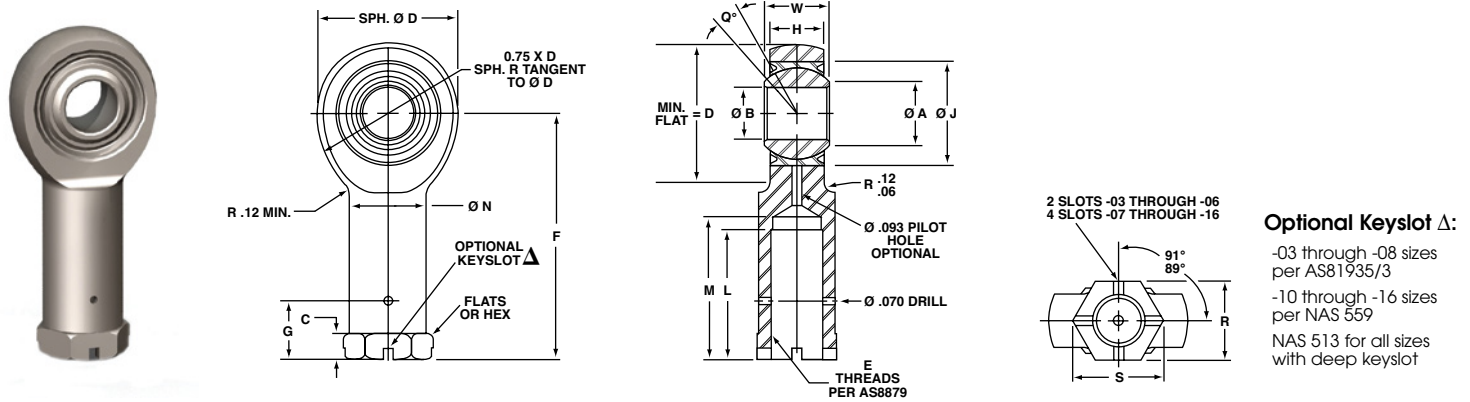

Optional Keyslot Δ:

- 03 through -08 sizes per AS81935/3
- 10 through -16 sizes per NAS 559
- NAS 513 for all sizes with deep keyslot

Δ For keyslot details, contact Astro's Product Engineering Group.

PART NUMBER	AS DASH NO.	(B) BORE DIA.	(D) SPH. DIA.	(W) BALL WIDTH	(H) BODY WIDTH	(A) SHOULDER DIA.	BALL DIA.	(F) BALL C/L TO END	(E) THREAD SIZE	(L) THREAD LENGTH	(N) SHANK DIA.	(M) DRILL DEPTH	(C) HEIGHT WRENCH SURFACE	(R) WIDTH ACROSS FLATS	(S) ACROSS CORNERS OR DIA.	(G) DRILL C/L TO END	(J) HOUSING I.D.	(O°) MIS-ALIGNMENT
M81935/7		+0.000 -0.005	+0.010 -0.010	+0.000 -0.002	+0.005 -0.005	MIN.	REF.	+0.010 -0.010	UNJF-3B	MIN.	+0.010 -0.010	MAX.	+0.010 -0.062	+0.010 -0.010	REF.	+0.020 -0.020	MAX.	MIN.
ADNC03	-03	.1900	.806	.437	.337	.300	.531	1.375	.3125-24	.750	.422	.875	.188	.437	.500	.375	.6250	15°
ADNC04	-04	.2500	.806	.437	.337	.300	.531	1.469	.3125-24	.750	.422	.875	.188	.437	.500	.375	.6250	15°
ADNC05	-05	.3125	.900	.437	.327	.360	.593	1.625	.3750-24	.875	.485	1.000	.250	.500	.580	.437	.6875	14°
ADNC06	-06	.3750	1.025	.500	.416	.470	.687	1.812	.3750-24	1.000	.547	1.125	.250	.562	.660	.437	.8125	8°
ADNC07	-07	.4375	1.150	.562	.452	.540	.781	2.000	.4375-20	1.125	.610	1.250	.250	.625	.720	.500	.9062	10°
ADNC08	-08	.5000	1.337	.625	.515	.610	.875	2.250	.5000-20	1.250	.735	1.375	.250	.750	.880	.562	1.0000	9°
ADNC10	-10	.6250	1.525	.750	.577	.750	1.062	2.500	.6250-18	1.375	.860	1.500	.375	.875	1.020	.687	1.1875	12°
ADNC12	-12	.7500	1.775	.875	.640	.850	1.250	2.875	.7500-16	1.625	.985	1.750	.375	1.000	1.160	.812	1.3750	13°
ADNC14	-14	.8750	2.025	.875	.765	1.000	1.375	3.375	.8750-14	1.875	1.110	2.062	.500	1.125	1.300	.937	1.6250	6°
ADNC16	-16	1.0000	2.775	1.375	1.015	1.270	1.875	4.125	1.2500-12	2.125	1.688	2.312	.563	1.750	2.020	1.312	2.1250	12°

Part Number Coding:

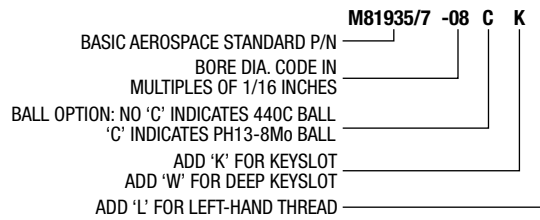
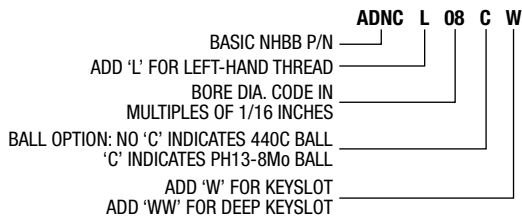

Notes:

- Bearings listed in the tables are approved for procurement to AS81935.
- Operating temperature range per AS81935: -65 to 325 °F. Broader temperature capabilities are achievable.
- All dimensions are in inches unless otherwise specified.

MATERIALS				
Part No.	Ball	Race	Liner	Body
Catalog No.	CRES 440C AMS 5630 55-62 HRC	CRES 17-4PH AMS 5643 28-37 HRC	PTFE/Fabric Bonded to Race I.D. No Lub. Required	PH13-8Mo AMS 5629 40-44 HRC
◆ Optional ball material:				
Catalog No. + C*	PH13-8Mo AMS 5629 43 HRC minimum hardness			

*See part number coding above.

PERFORMANCE PROPERTIES – WIDE						
AS Dash No.	AS Dash No.	No Load Rotational Breakaway Torque	Ultimate Static Radial Load	Axial Static Proof Load	Fatigue Load	Approx. Weight
		In-lbs.	lbs.	lbs.	lbs.	lbs.
M81935/7						
ADNC03	-03	.5-6	2,360	1,000	1,470*	.080
ADNC04	-04	.5-6	4,860	1,000	2,380	.084
ADNC05	-05	1-15	7,180	1,100	3,020	.102
ADNC06	-06	1-15	8,550	1,660	3,570	.161
ADNC07	-07	1-15	12,000	1,850	4,800	.212
ADNC08	-08	1-15	19,500	2,040	8,260	.325
ADNC10	-10	1-15	21,900	2,430	9,180	.481
ADNC12	-12	1-15	29,300	2,810	11,600	.673
ADNC14	-14	1-24	34,500	3,320	13,100	.959
ADNC16	-16	1-24	80,300	4,340	30,400	2.717

*Based on bolt bending fatigue strength 180,000 psi.



Corrosion Resistant (CRES) – AS81935/8

Narrow—Male Thread

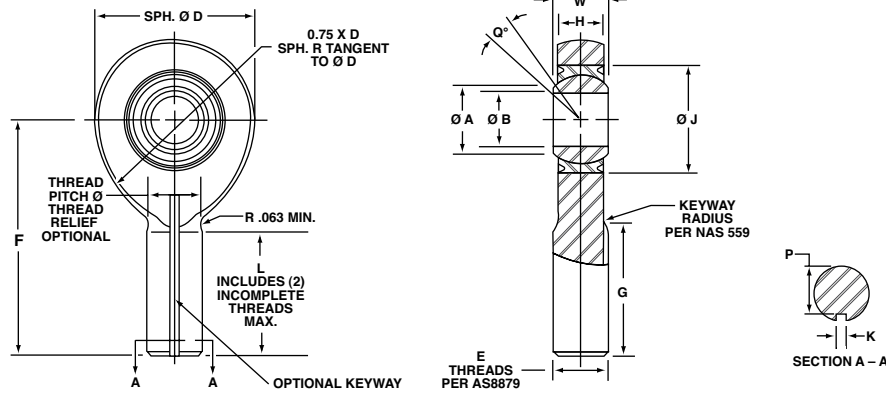

Optional Keyway:

- 03 through -08 sizes per AS81935/3
- 10 through -16 sizes per NAS 559

PART NUMBER	AS DASH NO.	(B) BORE DIA.	(D) SPH. DIA.	(W) BALL WIDTH	(H) BODY WIDTH	(A) SHOULDER DIA.	BALL DIA.	(F) BALL C/L TO END	(E) THREAD SIZE	(L) THREAD LENGTH	(J) HOUSING I.D.	(G) KEYWAY FLAT	(K) KEYWAY WIDTH	(P) KEYWAY	(Ø) MIS-ALIGNMENT
M81935/8		+0.000 -0.0005	+0.010 -0.010	+0.000 -0.002	+0.005 -0.005	MIN.	REF.	+0.010 -0.010	UNJF-3A	+0.031 -0.031	MAX.	+0.000 -0.020	+0.005 -0.000	+0.000 -0.005	MIN.
ADNEC03-382	-03	.1900	.680	.281	.228	.293	.437	1.315	.2500-28	.775	.5625	.896†	.062	.207	10°
ADNEC04-382	-04	.2500	.827	.343	.260	.364	.531	1.443	.2500-28	.775	.6562	.896	.062	.207	10°
ADNEC05-382	-05	.3125	.984	.375	.291	.419	.562	1.948	.3125-24	1.187	.7500	1.308	.062	.268	10°
ADNEC06-382	-06	.3750	1.131	.406	.322	.475	.656	2.030	.3750-24	1.187	.8125	1.308	.093	.319	9°
ADNEC07-382	-07	.4375	1.294	.437	.353	.530	.718	2.250	.4375-20	1.281	.9062	1.402	.093	.383	8°
ADNEC08-382	-08	.5000	1.459	.500	.400	.600	.813	2.544	.5000-20	1.468	1.0000	1.589	.093	.445	8°
ADNEC10-382	-10	.6250	1.763	.625	.510	.739	.968	2.832	.6250-18	1.562	1.1875	1.683	.125	.541	8°
ADNEC12-382	-12	.7500	2.140	.750	.603	.920	1.187	3.193	.7500-16	1.687	1.4375	1.808	.125	.663	8°
ADNEC14-382	-14	.8750	2.372	.875	.713	.980	1.312	3.677	.8750-14	2.000	1.5625	2.121	.156	.777	8°
ADNEC16-382	-16	1.0000	2.681	1.000	.807	1.118	1.500	3.968	1.0000-12	2.100	1.7500	2.221	.156	.900	9°

† Keyway Flat (G) tolerance for ADNEC03-382 is +.000/-0.060.

Part Number Coding:

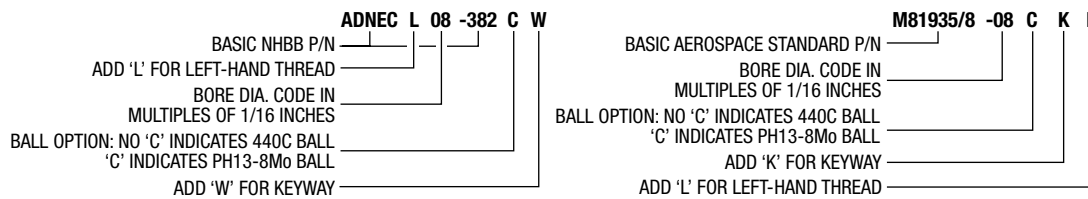

Notes:

- Bearings listed in the tables are approved for procurement to AS81935.
- Operating temperature range per AS81935: -65 to 325 °F. Broader temperature capabilities are achievable.
- All dimensions are in inches unless otherwise specified.

MATERIALS				
Part No.	Ball	Race	Liner	Body
Catalog No.	CRES 440C AMS 5630 55-62 HRC	CRES 17-4PH AMS 5643 28-37 HRC	PTFE/Fabric Bonded to Race I.D. No Lub. Required	PH13-8Mo AMS 5629 40-44 HRC
♦ Optional ball material:				
Catalog No. + C*	PH13-8Mo AMS 5629 43 HRC minimum hardness			

*See part number coding above.

PERFORMANCE PROPERTIES – NARROW						
M81935/8	AS Dash No.	No Load Rotational Breakaway Torque	Ultimate Static Radial Load	Axial Static Proof Load	Fatigue Load	Approx. Weight
		In-lbs.	lbs.	lbs.	lbs.	lbs.
ADNEC03-382	-03	.5-6	3,000	150	1,100	.045
ADNEC04-382	-04	.5-6	5,300	430	1,500	.060
ADNEC05-382	-05	1-15	8,600	700	2,400	.100
ADNEC06-382	-06	1-15	13,000	1,100	3,600	.135
ADNEC07-382	-07	1-15	17,800	1,400	5,000	.200
ADNEC08-382	-08	1-15	24,200	2,040	6,800	.285
ADNEC10-382	-10	1-15	38,500	2,430	10,800	.505
ADNEC12-382	-12	1-15	56,600	2,940	16,000	.830
ADNEC14-382	-14	1-24	77,400	3,190	21,900	1.235
ADNEC16-382	-16	1-24	101,400	3,570	28,600	1.725



Corrosion Resistant (CRES) – AS81935/9

Narrow—Female Thread

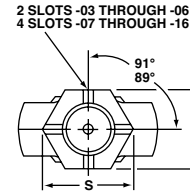
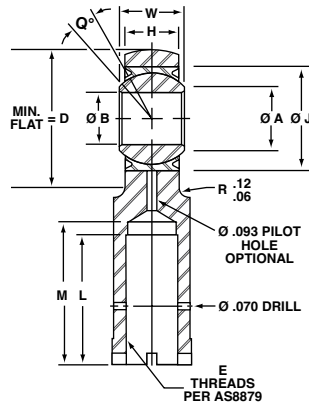
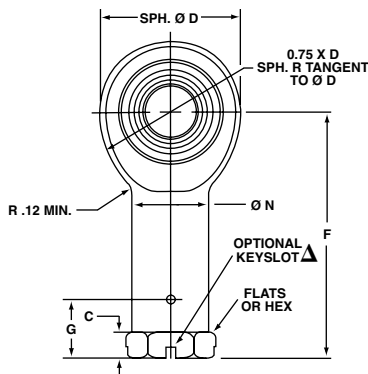

Optional Keyslot Δ:

- 03 through -08 sizes per AS81935/3
- 10 through -16 sizes per NAS 559
- NAS 513 for all sizes with deep keyslot

Δ For keyslot details, contact Astro's Product Engineering Group.

PART NUMBER	AS DASH NO.	(B) BORE DIA.	(D) SPH. DIA.	(W) BALL WIDTH	(H) BODY WIDTH	(A) SHOULDER DIA.	BALL DIA.	(F) BALL C/L TO END	(E) THREAD SIZE	(L) THREAD LENGTH	(N) SHANK DIA.	(M) DRILL DEPTH	(C) HEIGHT WRENCH SURFACE	(R) WIDTH ACROSS FLATS	(S) ACROSS CORNERS OR DIA.	(G) DRILL C/L TO END	(J) HOUSING I.D.	(0°) MIS-ALIGNMENT
M81935/9		+0.000 -0.005	+0.010 -0.010	+0.000 -0.002	+0.005 -0.005	MIN.	REF.	+0.010 -0.010	UNJF-3B	MIN.	+0.010 -0.010	MAX.	+0.010 -0.062	+0.010 -0.010	REF.	+0.020 -0.020	MAX.	MIN.
ADNC03-345	-03	.1900	.680	.281	.228	.293	.437	1.210	.2500-28	.625	.329	.750	.188	.375	.430	.312	.5625	10°
ADNC04-345	-04	.2500	.827	.343	.260	.364	.531	1.338	.2500-28	.625	.329	.750	.188	.375	.430	.312	.6562	10°
ADNC05-345	-05	.3125	.984	.375	.291	.419	.562	1.566	.3125-24	.750	.413	.875	.188	.437	.500	.375	.7500	10°
ADNC06-345	-06	.3750	1.131	.406	.322	.475	.656	1.908	.3750-24	1.000	.501	1.125	.250	.625	.720	.437	.8125	9°
ADNC07-345	-07	.4375	1.294	.437	.353	.530	.718	2.125	.4375-20	1.125	.584	1.250	.250	.625	.720	.500	.9062	8°
ADNC08-345	-08	.5000	1.459	.500	.400	.600	.813	2.356	.5000-20	1.250	.672	1.375	.375	.875	1.020	.562	1.0000	8°
ADNC10-345	-10	.6250	1.763	.625	.510	.739	.968	2.707	.6250-18	1.375	.845	1.500	.375	.875	1.020	.687	1.1875	8°
ADNC12-345	-12	.7500	2.140	.750	.603	.920	1.187	3.193	.7500-16	1.625	1.017	1.750	.500	1.125	1.300	.812	1.4375	8°
ADNC14-345	-14	.8750	2.372	.875	.713	.980	1.312	3.677	.8750-14	1.875	1.187	2.062	.500	1.250	1.375	.937	1.5625	8°
ADNC16-345	-16	1.0000	2.681	1.000	.807	1.118	1.500	4.101	1.0000-12	2.125	1.356	2.312	.500	1.375	1.590	1.062	1.7500	9°

Part Number Coding:

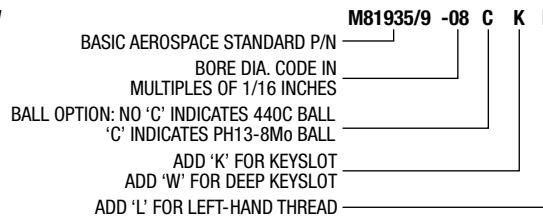
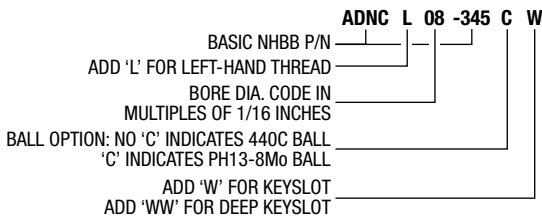

Notes:

- Bearings listed in the tables are approved for procurement to AS81935.
- Operating temperature range per AS81935: -65 to 325 °F. Broader temperature capabilities are achievable.
- All dimensions are in inches unless otherwise specified.

MATERIALS				
Part No.	Ball	Race	Liner	Body
Catalog No.	CRES 440C♦ AMS 5630 55-62 HRC	CRES 17-4PH AMS 5643 28-37 HRC	PTFE/Fabric Bonded to Race I.D. No Lub. Required	PH13-8Mo AMS 5629 40-44 HRC
♦Optional ball material:				
Catalog No. + C*	PH13-8Mo AMS 5629 43 HRC minimum hardness			

* See part number coding above.

PERFORMANCE PROPERTIES – NARROW							
AS Dash No.	M81935/9	AS Dash No.	No Load Rotational Breakaway Torque	Ultimate Static Radial Load	Axial Static Proof Load	Fatigue Load	Approx. Weight
			In-lbs.	lbs.	lbs.	lbs.	lbs.
	ADNC03-345	-03	.5-6	3,000	150	1,100	.080
	ADNC04-345	-04	.5-6	5,500	430	1,300	.084
	ADNC05-345	-05	1-15	8,900	700	2,000	.102
	ADNC06-345	-06	1-15	13,400	1,100	3,100	.161
	ADNC07-345	-07	1-15	18,200	1,400	4,200	.212
	ADNC08-345	-08	1-15	24,600	2,040	5,700	.325
	ADNC10-345	-10	1-15	39,500	2,430	9,200	.481
	ADNC12-345	-12	1-15	57,200	2,940	13,500	.673
	ADNC14-345	-14	1-24	77,800	3,100	18,400	.959
	ADNC16-345	-16	1-24	101,000	3,570	24,000	2.717

Astro Division, Laconia, NH

Astro designs and manufactures highly specialized custom bearings, next-up assemblies, and machined parts requiring significant engineering expertise and specialty materials. Our stringent process controls and advanced planning system enable us to satisfy unique production requirements and provide improved delivery scheduling as part of our continuous improvement culture and commitment to customer satisfaction.

PRODUCTS

- Rod ends
- Sphericals
- Link assemblies
- Bushings
- Loader slot bearings
- Custom-lined parts
- Bearings up to 22" O.D.
- Next-up assemblies & machined parts

NMB, KARUIZAWA, JAPAN*

- Rod ends
- Sphericals
- Spherical roller bearings
- Self-aligning roller bearings
- Next-up assemblies & machined parts

QUALITY CERTIFICATIONS

- ISO 9001:2008
- AS9100, Rev C
- Boeing D6-82479
- FAA FAR 21.303

NADCAP

- AC7102 – Heat-treating
- AC7108 – Chemical processing
- AC7114 – Nondestructive testing
- AC7118 – Composites/bonding

ENVIRONMENTAL MANAGEMENT CERTIFICATION

- ISO 14001:2004

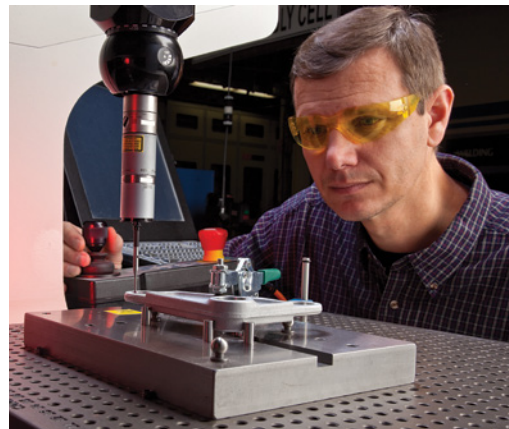

*Astro is the North American sales representative for products manufactured by NMB's facility in Karuizawa, Japan, giving customers access to a global supply of high quality commercial aerospace parts.



New Hampshire Ball Bearings, Inc.

————— ***A Minebea Company*** —————

Astro Division

155 Lexington Drive

Laconia, NH 03246

tel: 603.524.0004 fax: 603.524.9025

Other NHBB Divisions

**Precision Division and
Corporate Headquarters**

9700 Independence Avenue

Chatsworth, CA 91311

tel: 818.993.4100 fax: 818.407.5020

HiTech Division

175 Jaffrey Road

Peterborough, NH 03458

tel: 603.924.4100 fax: 603.924.4419

myonic USA

9700 Independence Avenue

Chatsworth, CA 91311

tel: 818.701.4833 fax: 818.407.5020

NHBB Europe

Siemensstrasse 30

63225 Langen

Germany

tel: (49) 6103.913.341 fax: (49) 6103.913.342

nhbb.com