

Inch Series

Torque Tube – Radial

Bore Sizes .6250-3.0625 inches

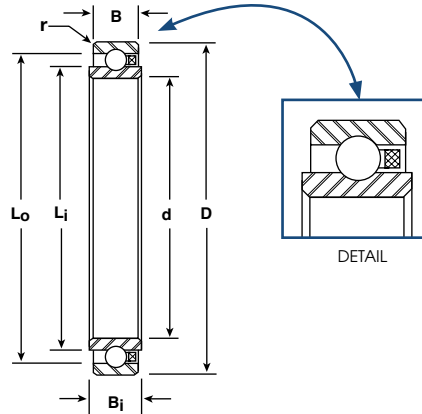

BASIC P/N	BORE d		O.D. D		WIDTH B				LAND DIAMETER (REFERENCE)		FILLET RADIUS r	BALL COMPLEMENT		LOAD RATINGS (LBS)		
	INCH	mm	INCH	mm	INNER B _i		OUTER B		L _i	L _o		NO.	SIZE INCH	RADIAL CAPACITY		THRUST CAPACITY STATIC
					INCH	mm	INCH	mm			DYN. C			STATIC C _o		
RI-538	.6250	15.875	1.0625	26.988	.2812	7.142	.2500	6.350	.773	.933	.015	12	1/8	655	379	271
RI-539	.7500	19.050	1.1875	30.162	.2812	7.142	.2500	6.350	.894	1.054	.015	12	1/8	645	391	272
RI-540	.8750	22.225	1.3125	33.338	.2812	7.142	.2500	6.350	1.019	1.179	.015	14	1/8	705	467	318
RI-541	1.0625	26.988	1.5000	38.100	.2812	7.142	.2500	6.350	1.210	1.368	.015	16	1/8	754	548	365
RI-542	1.3125	33.338	1.7500	44.450	.2812	7.142	.2500	6.350	1.460	1.618	.015	18	1/8	780	632	411
RI-543	1.5625	39.688	2.0000	50.800	.2812	7.142	.2500	6.350	1.706	1.866	.015	25	1/8	935	893	573
RI-544	1.8125	46.038	2.2500	57.150	.2812	7.142	.2500	6.350	1.963	2.123	.015	29	1/8	998	1050	665
RI-545	2.0625	52.388	2.6250	66.675	.2812	7.142	.2500	6.350	2.263	2.423	.015	32	1/8	1028	1172	735
RI-546	2.3125	58.738	2.8750	73.025	.2812	7.142	.2500	6.350	2.513	2.674	.015	34	1/8	1044	1255	794
RI-547	2.5625	65.088	3.2500	82.550	.3750	9.525	.3120	7.925	2.793	3.024	.015	26	3/16	1954	2113	1778
RI-548	2.8125	71.438	3.5000	88.900	.3750	9.525	.3120	7.925	3.043	3.275	.015	28	3/16	2011	2293	1818
RI-549	3.0625	77.788	3.8750	98.425	.3750	9.525	.3120	7.925	3.352	3.589	.015	32	3/16	2147	2652	2031

Notes:

1. Torque tube radial ball bearings are typically manufactured from 440C stainless steel.
2. Load ratings shown are for 52100 chrome steel.
3. The standard retainer design is a phenolic crown. Please check with NHBB for availability of other retainer options.
4. Standard tolerances are ABEC 5T per ABMA Standard 12. ABEC 7T tolerances are also available.
5. Fillet Radius (r) is the maximum shaft or housing fillet radius that bearing corners will clear.