

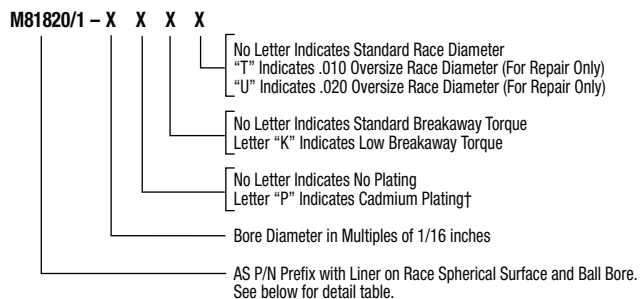

AS81820 Lined Bore Series – Wide

Aerospace Standard P/N



NHBB P/N

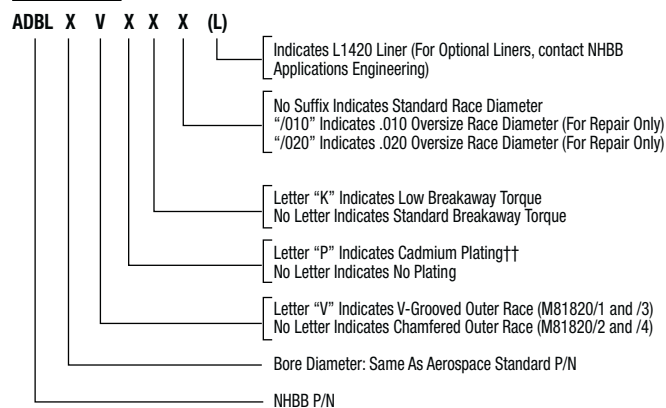

† Cadmium plate M81820/1 & M81820/3 O.D. and on the flats between the outside diameter and the grooves per AMS-QQ-P-416, Type II, Class 2. Dimensions apply after plating.

†† Cadmium plate M81820/2 & M81820/4 O.D. and O.D. chamfers per AMS-QQ-P-416, Type II, Class 2. Dimensions apply after plating.

Aerospace Standard P/N	NHBB P/N	Description
M81820/1	ADBL V	Narrow Grooved
M81820/2	ADWL	Wide Chamfered
M81820/3	ADWL V	Wide Grooved
M81820/4	ADBL	Narrow Chamfered

Part Number	MS Dash No.	(B) Bore Diameter	(D) Outside Diameter	(W) Ball Width	(T) Race Width	Ball Diameter	(E) Pitch Diameter	(P) Groove Depth	(Q°) Mis-alignment	Limit Static Radial Load	Limit Static Axial Load	Dynamic Osc. Radial Load	Weight
M81820/2		Inch	Inch	Inch	Inch	Inch	Inch	Inch	Degree	lbs.	lbs.	lbs.	lbs.
M81820/3		+0.000	+0.000	+0.000	±.005	Ref.	+0.000	+0.000	Ref.				Ref.
		-0.010	-0.0005	-0.002			-0.008	-0.010					
ADWL5V(L)	-5	.3135	.6875	.437	.317	.593	.625	.025	14°	9250	1640	4450	.035
ADWL6V(L)	-6	.3760	.8125	.500	.406	.687	.712	.035	8°	13000	2630	6200	.060
ADWL7V(L)	-7	.4385	.9375	.562	.442	.781	.837	.035	10°	17300	3650	8250	.080
ADWL7V52(L)	-7A	.4385	.9062	.562	.442	.781	.806	.035	10°	17250	3650	8250	.080
ADWL8V(L)	-8	.5010	1.0000	.625	.505	.875	.900	.035	9°	21400	4970	10600	.100
ADWL9V(L)	-9	.5635	1.1250	.687	.536	1.000	1.025	.035	10°	26600	5370	13200	.135
ADWL10V(L)	-10	.6260	1.1875	.750	.567	1.062	1.087	.035	12°	29000	6130	16150	.160
ADWL12V(L)	-12	.7510	1.3750	.875	.630	1.250	1.251	.055	13°	37000	7730	24800	.240
ADWL14V(L)	-14	.8760	1.6250	.875	.755	1.375	1.501	.055	6°	56000	10800	26750	.350
ADWL16V(L)	-16	1.0010	2.1250	1.375	1.005	1.875	2.001	.055	12°	103300	19300	49300	.970
ADWL18V(L)	-	1.1260	2.2500	1.437	1.067	1.968	2.126	.055	14°	120410	19640	48760	1.000
ADWL20V(L)	-	1.2510	2.3750	1.500	1.130	2.093	2.251	.055	13°	139690	21970	56620	1.120
ADWL20-5V(L)	-	1.2510	2.0000	1.093	.942	1.781	1.876	.055	6°	101540	14890	40840	.564
ADWL22V(L)	-	1.3760	2.5625	1.687	1.223	2.281	2.438	.055	15°	172940	25970	70250	1.390
ADWL24V(L)	-	1.5010	2.6875	1.687	1.223	2.390	2.563	.055	14°	188670	25970	76640	1.480

*For chamfered version, delete "V" from part number.

No Load Breakaway Torque

Bore Sizes	Standard (in - lbs.)	"K" Type
4 (Narrow only)	1.0 to 5.0	0 to 0.5
5 to 12	1.0 to 15.0	0 to 1.0
14 to 24	1.0 to 25.0	0 to 2.0

Radial and Axial Play

P/N Series M81820/1 & M81820/4		
Bore Size	Max. Radial Play	Max. Axial Play
3K Thru 12K	0.0007 Inch	0.0028 Inch
14K Thru 16K	0.0010 Inch	0.0040 Inch

P/N Series M81820/2 & M81820/3		
Bore Size	Max. Radial Play	Max. Axial Play
3K Thru 12K	0.0007 Inch	0.0021 Inch
14K Thru 16K	0.0010 Inch	0.0030 Inch