

SLEEVE BEARINGS – Self-Lubricating

AS81934 Flanged

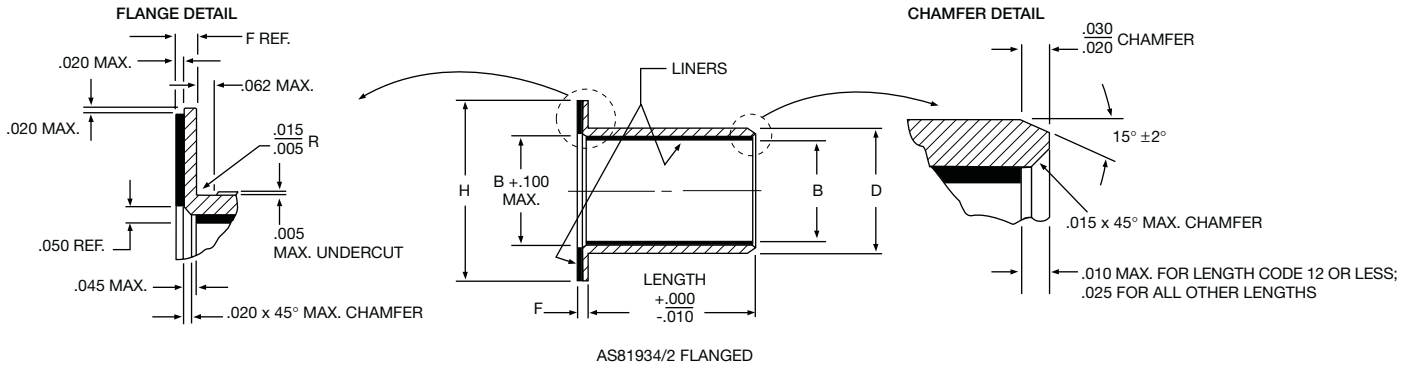

AS81934/2 FLANGED

Part Number	(B) Bore Diameter	(D) Outside Diameter			(H) Flange Diameter	(F) Flange Thickness	Approx. Sleeve Weight LB. In. (Ref.) L = 1.000		Flange Weight lbs. (Ref.)	
		Alum. Tol. +.0005/- .0005 Standard	CRES Tol. +.0000/- .0005 1st Oversize	2nd Oversize			Alum.	CRES	Alum.	CRES
	Inch				Inch	Inch	Inch	Inch	lb/in	lb/in
M81934/2	+ .0000 - .0010				+ .000 - .020	+ .000 - .005	- .005 - .005			
ADLF04	.2512	.3760	.3860	.3960	.750	.0625	.006	.016	.002	.006
ADLF05	.3140	.4386	.4486	.4586	.812	.0625	.007	.019	.003	.007
ADLF06	.3765	.5012	.5112	.5212	.875	.0625	.008	.022	.003	.007
ADLF07	.4390	.5638	.5738	.5838	.937	.0625	.009	.025	.003	.008
ADLF08	.5015	.6265	.6365	.6465	1.000	.0625	.011	.028	.003	.009
ADLF09	.5640	.6892	.6992	.7092	1.125	.0625	.012	.031	.004	.011
ADLF10	.6265	.8142	.8242	.8342	1.250	.0625	.021	.056	.005	.014
ADLF11	.6890	.8767	.8867	.8967	1.375	.0625	.022	.060	.006	.016
ADLF12	.7515	.9393	.9493	.9593	1.500	.0625	.024	.065	.007	.020
ADLF14	.8765	1.0645	1.0745	1.0845	1.625	.0625	.028	.075	.008	.022
ADLF16	1.0015	1.1898	1.1998	1.2098	1.750	.0625	.031	.084	.009	.024
ADLF18	1.1265	1.3148	1.3248	1.3348	1.875	.0937	.035	.094	.015	.041
ADLF20	1.2515	1.4398	1.4498	1.4598	2.000	.0937	.038	.103	.016	.045
ADLF22	1.3765	1.5648	1.5748	1.5848	2.125	.0937	.041	.113	.017	.048
ADLF24	1.5015	1.7523	1.7623	1.7723	2.250	.0937	.062	.171	.018	.051
ADLF26	1.6265	1.8773	1.8873	1.8973	2.375	.0937	.067	.183	.020	.055
ADLF28	1.7515	2.0023	2.0123	2.0223	2.500	.0937	.071	.196	.021	.058
ADLF32	2.0015	2.2523	2.2623	2.2723	2.750	.0937	.081	.222	.023	.065

Notes:

- Static Limit Load:
Alum., 50,000 psi X B(L + F - .13) = lbs.
CRES, 78,500 psi X B(L + F - .13) = lbs.
- Dynamic Capacity: 37,500 X B(L + F - .13) = lbs.
- Temperature: Operating temperature range -65° to 325°F.
- Concentricity tolerance between B and D diameters shall not exceed .003 FIM.
- Bearings listed in table are approved for procurement to AS81934.

Materials

Material Code	Sleeve	Liner
A	Aluminum Alloy 2024-T851 or 2024-T8511 per AMS-QQ-A-225/6 or AMS-QQ-A-200/3. Finish Anodized per AMS-A-8625, Type I or II or Alodine per AMS-C-5541	TEFLON®/Fabric Bonded to Bore and Flange Face. No Lub. Required.
C	CRES 17-4PH H.T. to Condition H-1150 per AMS-H-6875	"

TEFLON® is a Du Pont registered trademark



Aerospace Standard P/N

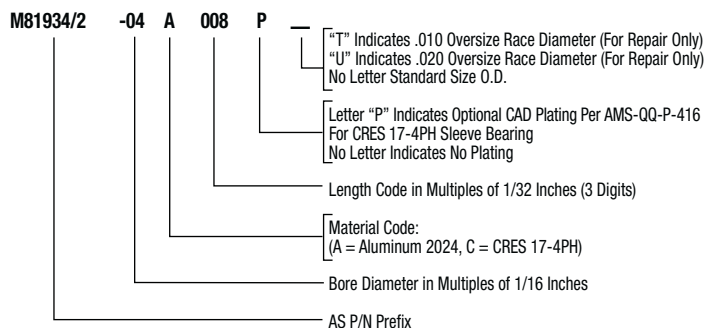

NHBB P/N

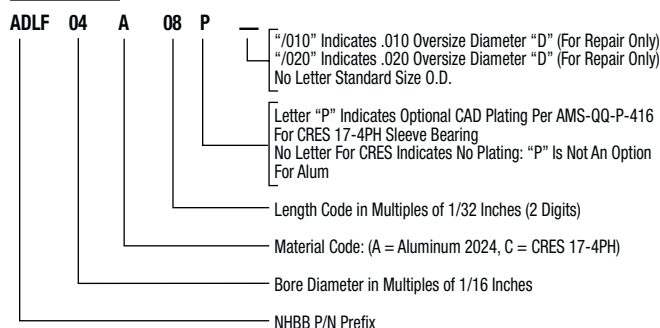

Length (Tolerance +.000, -.010)

Bore Code	5/32	3/16	7/32	1/4	9/32	5/16	11/32	3/8	7/16	1/2	9/16	5/8	11/16	3/4	7/8	1	1 1/8	1 1/4	1 3/8	1 1/2	1 5/8	1 3/4	1 7/8	2	2 1/8	2 1/4	2 3/8	2 1/2	2 3/4	3
04	05	06	07	08	09	10	11	12	14																					
05	05	06	07	08	09	10	11	12	14	16	18																			
06	05	06	07	08	09	10	11	12	14	16	18	20	22																	
07	05	06	07	08	09	10	11	12	14	16	18	20	22	24	28															
08	05	06	07	08	09	10	11	12	14	16	18	20	22	24	28															
09	05	06	07	08	09	10	11	12	14	16	18	20	22	24	28	32	36													
10	05	06	07	08	09	10	11	12	14	16	18	20	22	24	28	32	36	40	44											
11				08	09	10	11	12	14	16	18	20	22	24	28	32	36	40	44	48	52									
12				08	09	10	11	12	14	16	18	20	22	24	28	32	36	40	44	48	52									
14				08	09	10	11	12	14	16	18	20	22	24	28	32	36	40	44	48	52									
16				08	09	10	11	12	14	16	18	20	22	24	28	32	36	40	44	48	52	56	60							
18					10	11	12	14	16	18	20	22	24	28	32	36	40	44	48	52	56	60								
20								12	14	16	18	20	22	24	28	32	36	40	44	48	52	56	60	64	68					
22								12	14	16	18	20	22	24	28	32	36	40	44	48	52	56	60	64	68					
24								12	14	16	18	20	22	24	28	32	36	40	44	48	52	56	60	64	68	72	76	80	88	
26										16	18	20	22	24	28	32	36	40	44	48	52	56	60	64	68	72	76	80	88	96
28										16	18	20	22	24	28	32	36	40	44	48	52	56	60	64	68	72	76	80	88	96
32										16	18	20	22	24	28	32	36	40	44	48	52	56	60	64	68	72	76	80	88	96

Shaft and Housing Information

For optimum performance with lined sleeve bearings, considerable care must be exercised in the design of housings and shafts. For extreme applications involving dissimilar materials, elevated temperatures, or extreme loads, contact NHBB Applications Engineering for application recommendations. The adjacent table applies to normal conditions.

	Shaft	Housing
Diameter	B - .001 to - .002	D - .0006 to - .0011
Taper and Roundness	Not to exceed .0005	Not to exceed .0005
Finish	8 max. Polished or honed after grind	
Hardness	Rc50 min.	