

## *Engineering*

---

<u>Materials</u> .....	33
<u>Cages</u> .....	34
<u>Shields and Seals</u> .....	36
<u>Roller Bearing Features</u> .....	37
<u>Radial Play, Axial Play, Contact Angle</u> .....	38
<u>Lubrication</u> .....	40
<u>Preload and Duplex Bearings</u> .....	42
<u>Load Ratings and Bearing Life</u> .....	43
<u>Testing</u> .....	45
<u>Tolerances</u> .....	46
<u>Temperature Conversion Table</u> .....	47
<u>Inch/Metric Conversion Tables</u> .....	48





## Materials

The choice of materials in the design of ball and roller bearings is critical. The proper choice of materials will maximize fatigue life, and specify corrosion resistance and operating temperature limits in addition to establishing speed properties. All environmental conditions must be considered and evaluated in order to make the correct material decisions.

NHBB maintains exacting metallurgical control of all materials from the originating mill through tightly controlled heat treatment and all manufacturing processes.

### Ring and Rolling Element Standard and Special Materials

The traditional materials used in rolling element bearings are 52100 chrome steel, 440C stainless steel, and

M-50 tool steel. These materials are heat treated to achieve optimum hardness and dimensional stability, and are suitable for most conditions.

For unique and extreme applications, NHBB has the capability of processing many special materials. Hybrid ball bearings, consisting of steel rings and silicon nitride balls are being used in applications involving ultra high speeds or high stiffness requirements. Cobalt-based alloys possess good oxidation resistance and hot hardness. High speed steels provide somewhat higher hot hardness than M-50. 440C Modified stainless steel can be used in high temperature applications where corrosion resistance is desired. The properties of base bearing materials can be enhanced by coatings such as thin dense chromium or titanium carbide and other surface applications.

### Material Properties

Material	Specification	Melt Method	Attributes
52100	AMS 6440	Vacuum Degassed	Available in Tube Form.
	AMS 6444	CEVM*	Premium Quality. Very Low Impurity Level.
440C	AMS 5880	Air Melt or Vacuum Degassed	Corrosion Resistance.
	AMS 5618	CEVM*	Premium Quality with Low Impurity Level.
M-50	AMS 6491	VIM/VAR**	Premium Quality High Temperature Capabilities.
440C Modified	AMS 5749	VIM/VAR**	Premium Quality. Corrosion Resistance. High Temperature Capabilities.
Cobalt-based Alloys	AMS 5759	CEVM*	Chemical Resistance. High Temperature Capabilities.

\*Consumable Electrode Vacuum Melted

\*\*Vacuum Induction Melted/Vacuum Arc Remelted

### Heat Treatment Properties

Material	Room Temp. Hardness (Rc)	Operating Temp. Limit (°F)‡	Heat Treatment Attributes
52100	60-64	300	Good Wear & Fatigue Properties.
	58-62	400	Improved Thermal Stability.
440C	58-62	250	Good Wear Properties.
	56-60	600	Thermal Stability with Corrosion Resistance.
M-50	60-64	800	Excellent Fatigue Properties. High Thermal Stability.
440C Modified	61-65	900	Excellent Wear Properties. High Thermal Stability.
Cobalt-based Alloys	50 min.	1600	Good Thermal Stability. Low Hardness Reduction at Elevated Temperature.

‡Consult NHBB Engineering for higher operating temperature requirements.







## Cages

The cage, also referred to as the retainer or separator, is the component part of the bearing that separates and positions the balls or rollers at approximately equal intervals around the bearing raceway. Thus, proper selection of a bearing cage is critical for meeting the load, speed and temperature requirements of your

specific application. In some cases, such as high load requirements, the choice may be a full complement design. NHBB should be contacted for optimum bearing design.

The most common bearing cages are shown below:

### For Radial Ball Bearings:

Description	‡	Design	Material	Max. Speed-dN*	Operating Temp Max.	Comments	Typical Applications
Two-Piece Stamped, Crimped. Inner, Outer or Ball Piloted.	R RD		Steel	150,000	900°F.	General purpose.	Industrial
Two-Piece Stamped, Riveted. Ball Piloted	R6		Steel	250,000	900°F.	General purpose. Higher speed than crimped design.	Motors, Generators.
Two-Piece Stamped, Riveted. Land Riding. Skirted	R5 R7		Phosphor Bronze	1,000,000	400°F.	High Speed.	Transmissions, Power Units.
One-Piece Machined Crown	KE KF		Phenolic	600,000	300°F.	Moderate speed. Can be Impregnated with Oil.	Medical, Machine Tools.
One-Piece Molded Crown	M6 M7		Nylon with Fiber Reinforcement	300,000	300°F.	Accepts Misalignment, Low Noise Level.	Industrial Applications, Textile Spindles, Motors.
Two-Piece Machined, Riveted	B1 B2		Bronze	1,000,000	500°F.	High Speed and Strength Capabilities.	Gearbox.
	S1 S2		Steel with Silver Plate	1,500,000	900°F.	Very High Speed/Strength Capabilities. Typically used with M-50 Rings and Balls.	Aircraft Engine & Gearbox.
	M3		Phenolic with Aluminum Side Plates	1,000,000	300°F.	High Speed. Can be Impregnated with Oil.	Starters/Generators, High-Speed Motors.





‡Typical Part Number Designation

\*dN is bore (in millimeters) X RPM



# Cages

## For Angular Contact, Gothic Arch, or Fractured Race Ball Bearings:

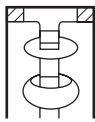
Description	‡	Design	Material	Max. Speed-dN*	Operating Temp Max.	Comments	Typical Applications
Machined One-Piece	KV KM		Laminated Paper or Linen Phenolic	1,500,000	300°F.	Can be Impregnated with Oil. High Speed, Quiet Running.	Spindles and High Speed Motors.
Molded One-Piece	MN		Nylon with Fiber Reinforcement	750,000	300°F.	Moderate Speed, General Purpose, Quiet Running.	Motors, Textile Spindles.
Machined One-Piece	MX		Bronze	1,500,000	500°F.	High Speed, Thin Cross Section, Good Strength.	Power Transmission, Aircraft Accessories.
Machined One-Piece	M2		Steel, with Silver Plate	3,000,000+	900°F.	Very High Speed & Strength.	Aircraft Accessories. High Speed Transmissions.
One-Piece Machined Inner or Outer Land Piloted with Ball Retention.	MP MQ		Bronze	1,000,000	350°F.	Good Strength, Moderate Speed.	Pump, Actuator, Accessory Gearbox.
	B5 B6		Silicon-Iron Bronze	2,000,000	500°F.	High Speed & Strength.	Gearboxes.
	S3 S4		Steel With Silver Plate	3,000,000+	900°F.	Very High Speed & Strength.	Mainshaft and Gearbox. High Reliability Applications.
	KS		Phenolic	1,500,000	300°F.	Can be Impregnated with Oil.	Motors and Spindles.

‡Typical Part Number Designation  
\*dN is bore (in millimeters) X RPM

## For Cylindrical Roller Bearings:

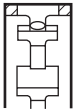
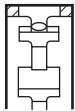
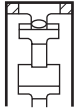
Description	‡	Design	Material	Max. Speed-dN*	Operating Temp Max.	Comments	Typical Applications
Machined One-Piece	S		Steel with Silver Plate	3,000,000+	900°F.	Very High Speed & Strength.	Mainshaft and Gearbox.
Machined One-Piece	B		80-10-10 Bronze or Equivalent	1,000,000	350°F.	Good Strength, Moderate Speed.	Pumps and Accessories.
Machined One-Piece	B		Silicone-Iron Bronze	1,500,000	500°F.	High Speed & Strength.	Gearboxes.

‡Typical Part Number Designation  
\*dN is bore (in millimeters) X RPM

## Shield and Seal Types





Seals and shields are used in ball bearings to retain lubricants and prevent contamination from reaching critical surfaces. NHBB manufactures a variety of closures to optimize the useful life of the bearing. Seals are generally used in high contamination environments where a positive closure is required. The use of seals will increase torque and heat generation and may affect operation speed limits. Shields provide a

labyrinth barrier to contamination without effecting speed and torque.

Consideration should be given to the compatibility of retainer and shield type designs to allow for appropriate clearance.

The following chart illustrates the most common types of shields and seals:

### Shield and Seal Types

Description	Type	Design	Material	Operating Temp Max.
Seal—Removable	D		Buna-N Bonded to Steel Insert	Limit of 250°F.
Seal—With snap wire	Q		Glass-reinforced Teflon	600°F.
Seal—Removable, noncontact	S1		Viton Bonded to Steel Insert	400°F.
Shield—Removable with snap wire	Z		Stainless Steel 300 Series	600°F.
Shield—Non-Removable	H		Stainless Steel 300 Series	600°F.



## Roller Bearing Features

NHBB manufactures cylindrical roller bearings in a wide range of designs and configurations. The tables on this page illustrate some typical specifications.

Please contact your HiTech sales and engineering groups to discuss specific requirements for your application.

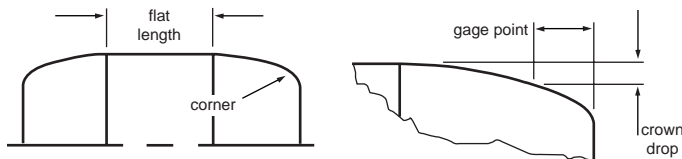

### Roller

Diameter & Length	EXAMPLES:		Corner
	Crown Drop	Flat Length	
5mm	Min: .0001" Max: .0003"	Min: .050" Max: .130"	.012-.018"
22mm	Min: .00070" Max: .00096"	Min: .300" Max: .540"	.030-.040"

### Roller Bearing Rings

Features	Standard
GUIDE FLANGES:	
- Finish-CLA	10
- Layback Angle Tolerance	1°
- Runout	.0003"
- Roller End Clearance Tolerance	.0010"
ROLLER PATHS:	
- Finish-CLA	8
- Straightness	.000050"
- Wall Thickness Variation	.0003"

### Cage/Roller Retention Comparison

Cage Style	Method of Manufacture	Control of Roller Drop	Reuse After Disassembly	NDT Inspection	Manufacturing Complexity
Roll Peened 	Prior to assembly, cage is "roll peened" to create retention.	Yields a relatively high roller drop as a function of roller diameter.	Yes.	All methods.	Low.
Line Staked 	After rollers are in place, line stake tool forms retention.	Tab is formed after assembly for close control of roller drop.	No. (Disassembly not possible.)	Visual only.	Moderate.
Fully Machined 	Roller retention is formed during broaching.	Yields a relatively high roller drop as a function of roller diameter.	Yes.	All methods.	High.

## Radial Play, Axial Play, and Contact Angle

### Ball Bearings

Most ball bearings are assembled in such a way that a slight amount of looseness exists between balls and raceways. This looseness is referred to as *radial play* and *axial play*. Specifically, **radial play** is the maximum distance that one bearing ring can be displaced with respect to the other, in a direction perpendicular to the bearing axis, when the bearing is in an unmounted state.

**Axial play**, or end play, is the maximum relative displacement between the two rings of an unmounted ball bearing in the direction parallel to the bearing axis.

Since radial play and axial play are both consequences of the internal geometry of the components in a ball bearing, they bear a mutual dependence.

The **contact angle** is the angle between a plane perpendicular to the ball bearing axis and a line joining the two points where the ball makes contact with the inner and outer raceways. The initial contact angle of the bearing is directly related to radial play — generally, the higher the radial play, the higher the contact angle.

The parameters of radial play, axial play, and contact angle are all interrelated, and their values are all mathematically interdependent. Operating conditions, such

### Radial Play

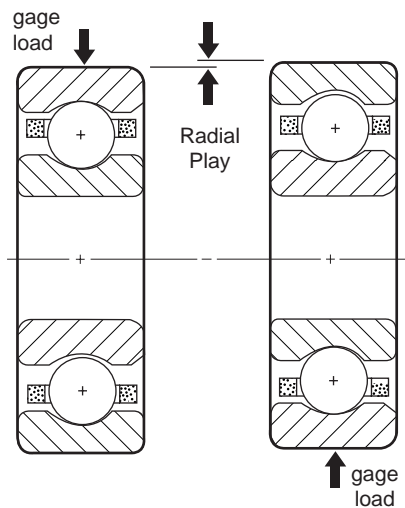

### Axial Play

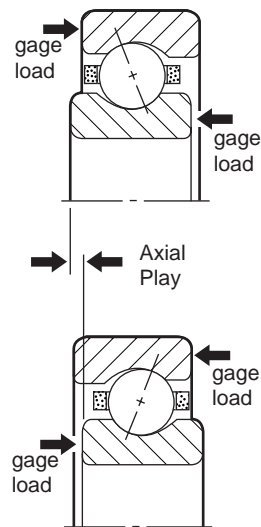

### Contact Angle

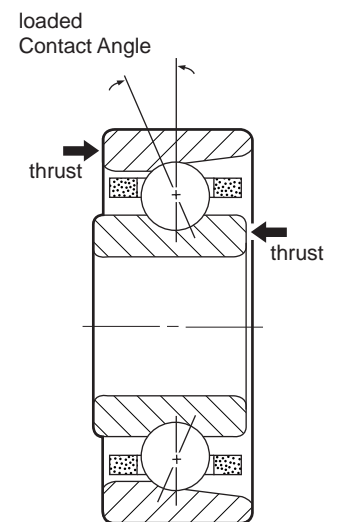



# Radial Play, Axial Play, and Contact Angle

## Ball Bearings (continued)

as radial or thrust loading and bearing torque, must be considered when specifying one of the above, along with the effect on the other two parameters.

The extremes of the various parameters (i.e., radial play, axial play, or contact angle) are dependent upon manufacturing tolerances. Additional information about these interrelationships can be obtained by contacting a member of our Engineering staff.

### Radial Play

$$P_D = 2Bd(1 - \cos \beta_0)$$

$$P_D = 2Bd - \sqrt{(2Bd)^2 - P_E^2}$$

### Axial Play

$$P_E = 2Bd \sin \beta_0$$

$$P_E = 2Bd - \sqrt{4BdP_D - P_D^2}$$

### Contact Angle

$$\beta_0 = \cos^{-1} \frac{2Bd - P_D}{2Bd}$$

$$\beta_0 = \sin^{-1} \frac{P_E}{2Bd}$$

$P_D$  = Radial play

$P_E$  = Axial play

$\beta_0$  = Contact angle

$B$  = Total curvature =  $(f_i + f_o - 1)$

$f_i$  = Inner ring curvature\*

$f_o$  = Outer ring curvature\*

$d$  = Ball diameter

\* Expressed as the ratio of race radius to ball diameter.

## Roller Bearings

While radial play in a roller bearing is the same as a ball bearing, **end play** is the maximum axial displacement of the roller element within the confines of the double guide flanged ring.

In a roller bearing, radial play and end play are totally independent of one another. Radial play is established for an unmounted condition, to account for shaft and housing press fits and operating temperature, all of which influence the mounted radial play. Ideally, a roller bearing will perform best with a minimum radial play. This condition distributes the load among the maximum number of rollers and will minimize the tendency for rollers to "skid" when passing through the no load zone. Close control of end play is required to minimize roller skewing, that is, to provide for optimum tracking at all speeds.

### Radial Play

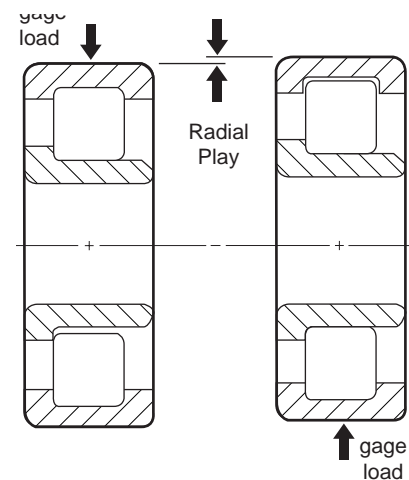

### End Play

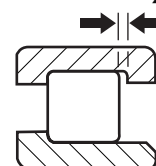

## *Lubrication*

---

Bearing lubrication reduces friction and wear, acts as a coolant, minimizes contamination, prevents corrosion, and generally extends bearing life. Selecting the best lubricant for your specific application becomes a very important decision; however, choosing from the hundreds available can be an overwhelming task. NHBB's engineering staff is available to help make the right choice for your application.

### **Oil**

Oil is the basic lubricant for ball and roller bearings. The main advantage of an oil lubricant is that there is less bearing torque. The use of synthetic oils such as diesters, silicone polymers, and fluorinated compounds has improved volatility and viscosity characteristics and increased temperature properties.

### **Grease**

Grease is an oil to which a thickener has been added to prevent oil migration from the lubrication site. It is used in situations where frequent replenishment of the

lubricant is undesirable or impossible. Generally, a grease can take higher loads and higher temperatures than an oil. All of the oil types mentioned in this section can be used as grease bases to which are added metallic soaps, synthetic fillers, and thickeners. The operative properties of grease depend almost wholly on the base oil.

### **Solid Film**

A solid film lubricant can range from simple sacrificial retainers, graphite, or molydisulfide powders, to complexion sputtering or plating. Each type must be engineered for the specific application. They are very useful in areas of temperature extremes, vacuum, radiation, pressure, or harsh environments where conventional lubricants would fail. Solid film lubricants do not deteriorate in storage.



# Lubrication

## Lubrication

NHBB Code	Brand Name	Type	Military Specification	Operating Temp Max.	General Comments
LO1	Windsor Lube L-245X	Diester, Synthetic Oil	MIL-L-6085	-65°F to 250°F.	Light general purpose instrument oil, low volatility.
LO2	Anderol L-401D	Diester, Synthetic Oil	MIL-L-6085	-65°F to 250°F.	Light general purpose instrument oil, low volatility.
LY115	Krytox 143AC	Fluorinated Oil		-30°F to 550°F.	High temperature stability.
LG20	Beacon 325	Diester, Synthetic Grease		-65°F to 250°F.	Nonchanneling. General purpose grease. NLGI 2*
LG39	Andok C	Petroleum Grease		-20°F to 250°F.	Channeling. Smooth running, long life with minimum migration. NLGI 4*
LY17	Rheotemp 500	Ester Grease		-65°F to 400°F.	High speed, high temp specialty lube; spindle, instrument, and aircraft bearings. NLGI 2*
LY48	Mobil 28	Petroleum Grease, Synthetic	MIL-G-81322	-85°F to 350°F.	Nonchanneling. Wide temperature range, good low temp torque. Aircraft, general purpose. NLGI 2*
LG4	Aeroshell 22	Petroleum Grease, Synthetic	MIL-G-81322	-85°F to 350°F.	Nonchanneling. Wide temperature range, good low temp torque. Aircraft, general purpose. NLGI 2*
LG68	Royco 27A	Diester Grease	MIL-G-23827	-65°F to 250°F.	General purpose, low volatility. NLGI 2*
LY101	Krytox 240AC	Fluorinated Grease		-30°F to 550°F.	High temperature stability. NLGI 2*
LY308	Braycote 601	Perfluorinated Polyether Grease		-112°F. to 400°F.	Wide temperature range, vacuum applications. NLGI 2*
LY223	Brayco Micronic 815Z	Perfluorinated Polyether Oil		-112°F. to 400°F.	Wide temperature range, vacuum applications.
LY51	Isoflex NBU15	Synthetic Oil Barium Complex Grease		-40°F to 265°F.	High Speed, spindle quality grease. NLGI 2*

\*National Lubricating Grease Institute—number refers to grease thickness.

## Preload and Duplex Bearings

Preload refers to the initial thrust load placed on a set of bearings during installation. Preload allows precise control over the operating geometry of the mating parts to the bearing, and is useful in applications where axial and radial movement must be held within critical limits.

In general, a “built-in preload” technique is used. When the set of bearings is assembled, the thrust load

needed to make the adjacent faces of the rings contact becomes the desired preload. “Built-in preload” helps satisfy the requirements of increased axial and radial stiffness and deflection control.

The three methods of mounting preloaded duplex bearings are back-to-back, face to face, and tandem.

When a **back-to-back** (DB) duplex pair is mounted, the inner rings are drawn together, providing increased stiffness.

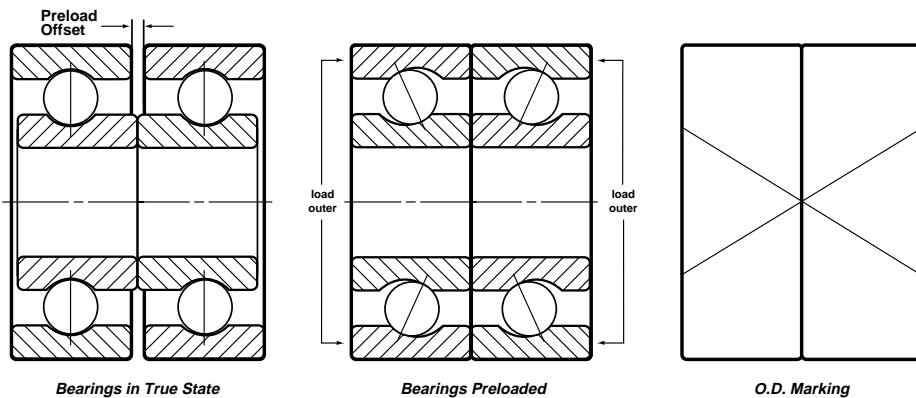
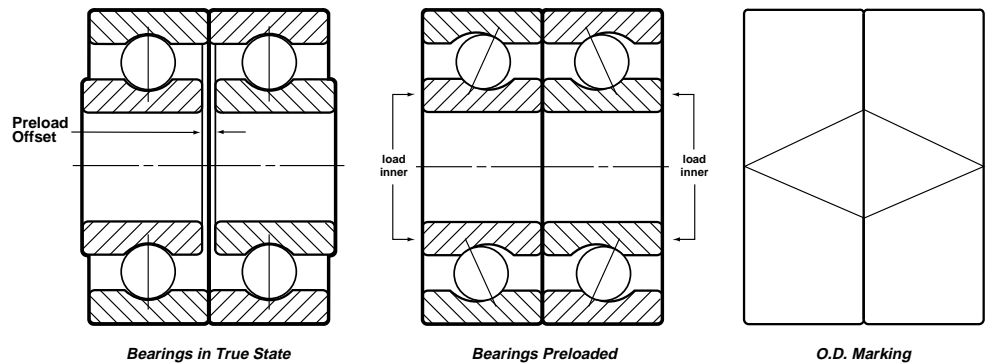

When **face-to-face** (DF) duplex pairs are mounted, the inner rings abut and outer rings are drawn together, providing a higher radial and axial stiffness and accommodation of misalignment.

With **tandem** (DT) pairs, both inner and outer rings abut and are capable of sharing a thrust load, providing increased thrust capacity.

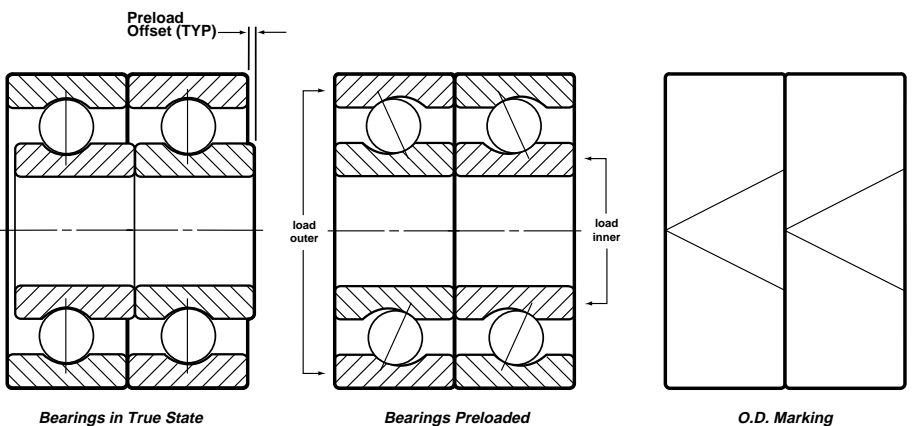



## Load Ratings and Bearing Life

The load ratings in this catalog are based on ANSI/ABMA Standards 9 and 11. These standards specify the accepted methods for calculating load ratings and fatigue life of ball and cylindrical roller bearings. Since a multitude of variables may affect these calculations, they should be used for baseline estimates only. Load ratings for your application's specific operating conditions should be calculated before making a final bearing choice.

### Basic Dynamic Load Rating

The Basic Load Rating (C) for a radial or angular contact ball bearing is a calculated constant radial load which a bearing with a stationary outer ring can theoretically endure for a rating life of 1,000,000 revolutions of the inner ring.

The ratings shown in this catalog are as defined by ANSI/ABMA STD-9 and STD-11. The ratings for non-catalog bearings may be determined by referring to this standard.

### Static Load Ratings

A static load is a load acting on a non-rotating bearing. Experience shows that a total permanent deformation of 0.0001 of the rolling element diameter, at the center of the most heavily loaded rolling element/raceway contact, can be tolerated in most bearing applications without the bearing operation being impaired. The basic static load rating is, therefore, that load which produces the above deformation.

As with the dynamic load ratings, the static rating determinations can be found in ANSI/ABMA STD-9 and STD-11.

### Rating Life

The "rating life"  $L_{10}$  of a group of apparently identical bearings is the life in millions of revolutions that 90 percent of the group will meet or exceed. For a single bearing,  $L_{10}$  also refers to the life associated with 90 percent reliability. The life which 50 percent of the group of bearings will meet or exceed, "median life" or  $L_{50}$ , is usually not greater than five times the rating life.

The calculation of rating life involves many parameters and is based on historical test data. Estimated rating life can best be determined by referring to ANSI/ABMA STD-9 and STD-11.

### Reliability

Where a more conservative approach than conventional rating life ( $L_{10}$ ) is desired, the ABMA offers a means for such estimates. The table below provides selected multipliers for calculating failure rates down to 1% ( $L_1$ ).

#### Life Adjustment Factors for Reliability

Reliability (%)	Rating Life	Life Adjustment Factor on Conventional Rating Life
90	$L_{10}$	1.00
95	$L_5$	0.62
96	$L_4$	0.53
97	$L_3$	0.44
98	$L_2$	0.33
99	$L_1$	0.21

## *Load Ratings and Bearing Life*

---

### **Material Factors**

Certain materials have proven to have greater fatigue life than others operating under identical conditions. The theoretical  $L_{10}$  dynamic life is based on air-melt steel and standard ABMA formulas. The life-adjustment factors for materials frequently used are shown below:

### ***Life Adjustment Factors for Material***

Material	Factor
M50	10
52100 VIM/VAR	7
52100 CEVM	5
440C Modified	3
52100	1
440C	.8

### **Other Life Adjustments**

The conventional rating life often has to be modified as a consequence of application abnormalities, whether they be intentional or unknown. Seldom are loads ideally applied. The following conditions all have the practical effect of modifying the ideal, theoretical rating life,  $L_{10}$ .

- a. Vibration and/or shock-impact loads.
- b. Angular misalignment.
- c. High speed.
- d. Operating at elevated temperatures.

NHBB can provide reliable bearing life estimates based on semi-empirical data to assist in accurately forecasting bearing life.



## Testing

---

### Engineering Test Laboratory

NHBB maintains a fully equipped engineering test laboratory to test and confirm the performance characteristics of bearing designs.

Thermal testing of materials and lubricants is done using both refrigeration and high temperature input to the test bearings.

Since significant rotational speed is a critical element in many of our customers' applications, NHBB uses high speed test spindles to evaluate bearing attributes (such as design, material, lubrication, etc.) and their effect on performance and life.

Bearing fatigue and load carrying capability is evaluated on an ongoing basis on endurance test rigs. Both continuous rotation and oscillation tests are performed under pre-established load conditions.

Testing of bearings in customer provided equipment provides the most realistic test conditions. NHBB engineers coordinate these tests with our customers to insure testing conditions are at least as demanding as the true application environment.

### Materials Laboratory

Our Materials Laboratory has been specifically designed and equipped to perform complex chemical, metallurgical, and visual analyses of the many component parts in ball and roller bearings. In addition to performing analyses on internal projects, this laboratory is available to perform wear and failure studies on customers' bearings.

Modern chemical analysis of organic compounds is carried out on a dual-beam infrared spectrophotometer. Likewise, alloy composition is determined with X-ray diffraction spectrography and nondestructive test methods.

Metallurgical studies can be made with a metallograph and microhardness testers. The metallograph will perform microstructure photography at magnifications from 25 to 2000 times, while microhardness testers investigate surface effects and alloy homogeneity using diamond identification methods.

During laboratory wear and failure analysis, bearings are disassembled and examined. All findings can be recorded permanently with a photo-microscope for analysis and future reference.

## Tolerances

NHBB is an active member in the American Bearing Manufacturers Association (ABMA) and its associated bearing technical committees—the Annular Bearing Engineers' Committee (ABEC) and the Roller Bearing Engineers' Committee (RBEC). With assistance from

ABEC, RBEC, and member management, the ABMA issues standards for bearing tolerances. Please consult with NHBB Engineering for Torque Tube and Thinex Bearing Tolerances.

### Inner Ring Tolerances

Tolerances in Inches														
Bore Size (mm)		Bore Diameter Tolerance ABEC/RBEC Class					Radial Runout Maximum ABEC/RBEC Class					Ring Width		
												ABEC 1 & 3	ABEC 5, 7 & 9	Duplex
OVER	INCL	1	3	5	7	9	1	3	5	7	9	SINGLE	SINGLE	INDIVIDUAL RING
–	10	.0003	.0003	.0002	.00015	.0001	.0004	.00025	.00015	.0001	.00005	.0047	.0016	.0098
10	18	.0003	.0003	.0002	.00015	.0001	.0004	.0003	.00015	.0001	.00005	.0047	.0031	.0098
18	30	.0004	.0003	.00025	.0002	.0001	.0005	.0003	.00015	.0001	.0001	.0047	.0047	.0098
30	50	.00045	.0004	.0003	.00025	.0001	.0006	.0004	.0002	.00015	.0001	.0047	.0047	.0098
50	80	.0006	.00045	.00035	.0003	.00015	.0008	.0004	.0002	.00015	.0001	.0059	.0059	.0098
80	120	.0008	.0006	.0004	.0003	.0002	.0010	.0005	.00025	.0002	.0001	.0079	.0079	.0150
120	180	.0010	.0007	.0005	.0004	.0003	.0012	.0007	.0003	.00025	.00015	.0098	.0098	.0150
180	250	.0012	.00085	.0006	.00045	.0003	.0016	.0008	.0004	.0003	.0002	.0118	.0118	.0197

### Outer Ring Tolerances

Tolerances in Inches														
Outside Diameter (mm)		Outside Diameter Tolerance ABEC/RBEC Class					Radial Runout Maximum ABEC/RBEC Class					Ring Width		
												ABEC 1 & 3	ABEC 5, 7 & 9	Duplex
OVER	INCL	1	3	5	7	9	1	3	5	7	9	SINGLE	SINGLE	INDIVIDUAL RING
18	30	.00035	.0003	.00025	.0002	.00015	.0006	.00035	.00025	.00015	.0001	.0047	.0016	.0098
30	50	.00045	.00035	.0003	.00025	.00015	.0008	.0004	.0003	.0002	.0001	.0047	.0031	.0098
50	80	.0005	.00045	.00035	.0003	.00015	.0010	.0005	.0003	.0002	.00015	.0047	.0047	.0098
80	120	.0006	.0005	.0004	.0003	.0002	.0014	.0007	.0004	.00025	.0002	.0047	.0047	.0098
120	150	.0007	.0006	.00045	.00035	.0002	.0016	.0008	.00045	.0003	.0002	.0059	.0059	.0098
150	180	.0010	.0007	.0005	.0004	.0003	.0018	.0009	.0005	.0003	.0002	.0079	.0079	.0150
180	250	.0012	.0008	.0006	.00045	.0003	.0020	.0010	.0006	.0004	.0003	.0098	.0098	.0150
250	315	.0014	.0010	.0007	.0005	.0003	.0024	.0012	.0007	.00045	.0003	.0118	.0118	.0197



# Temperature Conversion Table

The numbers in the center column refer to the temperatures either in Celsius or Fahrenheit which need conversion to the other scale. When converting from Fahrenheit to Celsius, the equivalent temperature will

be found to the left of the center column. If converting from Celsius to Fahrenheit, the answer will be found to the right.

## Celsius to Fahrenheit Conversion Table

°C	°F/°C	°F	°C	°F/°C	°F	°C	°F/°C	°F	°C	°F/°C	°F
-79	-110	-166	37.7	100	212	204	400	752	371	700	1292
-73	-100	-148	43	110	230	210	410	770	376	710	1310
-68	-90	-130	49	120	248	215	420	788	382	720	1328
-62	-80	-112	54	130	266	221	430	806	387	730	1346
-57	-70	-94	60	140	284	226	440	824	393	740	1364
-51	-60	-76	65	150	302	232	450	842	399	750	1382
-46	-50	-58	71	160	320	238	460	860	404	760	1400
-40	-40	-40	76	170	338	243	470	878	410	770	1418
-34	-30	-22	83	180	356	249	480	896	416	780	1436
-29	-20	-4	88	190	374	254	490	914	421	790	1454
-23	-10	14	93	200	392	260	500	932	427	800	1472
-17.7	0	32	99	210	410	265	510	950	432	810	1490
-17.2	1	33.8	104	220	428	271	520	968	438	820	1508
-16.6	2	35.6	110	230	446	276	530	986	443	830	1526
-16.1	3	37.4	115	240	464	282	540	1004	449	840	1544
-15.5	4	39.2	121	250	482	288	550	1022	454	850	1562
-15.0	5	41.0	127	260	500	293	560	1040	460	860	1580
-14.4	6	42.8	132	270	518	299	570	1058	466	870	1598
-13.9	7	44.6	138	280	536	304	580	1076	471	880	1616
-13.3	8	46.4	143	290	554	310	590	1094	477	890	1634
-12.7	9	48.2	149	300	572	315	600	1112	482	900	1652
-12.2	10	50.5	154	310	590	321	610	1130	488	910	1670
-6.6	20	68	160	320	608	326	620	1148	493	920	1688
-1.1	30	86	165	330	626	332	630	1166	499	930	1706
4.4	40	104	171	340	644	338	640	1184	504	940	1724
9.9	50	122	177	350	662	343	650	1202	510	950	1742
15.6	60	140	182	360	680	349	660	1220	516	960	1760
21.0	70	158	188	370	698	354	670	1238	521	970	1778
26.8	80	176	193	380	716	360	680	1256	527	980	1796
32.1	90	194	199	390	734	365	690	1274	532	990	1814

## Inch/Metric Conversion Table

Example: To look up the inch equivalent of 15mm, find 10 on the horizontal axis and 5 on the vertical axis.

Their intersection is the inch equivalent.  
15mm = .59055 inch. 1 inch = 25.4mm

### Millimeters to Inches

mm	0	10	20	30	40	50
0	0.0000	0.39370	0.78740	1.18110	1.57480	1.96850
1	0.03937	0.43307	0.82677	1.22047	1.61417	2.00787
2	0.07874	0.47244	0.86614	1.25984	1.65354	2.04724
3	0.11811	0.51181	0.90551	1.29921	1.69291	2.08661
4	0.15748	0.55118	0.94488	1.33858	1.73228	2.12598
5	0.19685	0.59055	0.98425	1.37795	1.77165	2.16535
6	0.23622	0.62992	1.02362	1.41732	1.81102	2.20472
7	0.27559	0.66929	1.06299	1.45669	1.85039	2.24409
8	0.31496	0.70866	1.10236	1.49606	1.88976	2.28346
9	0.35433	0.74803	1.14173	1.53543	1.92913	2.32283
mm	60	70	80	90	100	110
0	2.36220	2.75591	3.14961	3.54331	3.93701	4.33071
1	2.40157	2.79528	3.18898	3.58268	3.97638	4.37008
2	2.44094	2.83465	3.22835	3.62205	4.01575	4.40945
3	2.48031	2.87402	3.26772	3.66142	4.05512	4.44882
4	2.51969	2.91339	3.30709	3.70079	4.09449	4.48819
5	2.55906	2.95276	3.34646	3.74016	4.13386	4.52756
6	2.59843	2.99213	3.38583	3.77953	4.17323	4.56693
7	2.63780	3.03150	3.42520	3.81890	4.21260	4.60630
8	2.67717	3.07087	3.46457	3.85827	4.25197	4.64567
9	2.71654	3.11024	3.50394	3.89764	4.29134	4.68504
mm	120	130	140	150	160	170
0	4.72441	5.11811	5.51181	5.90551	6.29921	6.69291
1	4.76378	5.15748	5.55118	5.94488	6.33858	6.73228
2	4.80315	5.19685	5.59055	5.98425	6.37795	6.77165
3	4.84252	5.23622	5.62992	6.02362	6.41732	6.81102
4	4.88189	5.27559	5.66929	6.06299	6.45669	6.85039
5	4.92126	5.31496	5.70866	6.10236	6.49606	6.88976
6	4.96063	5.35433	5.74803	6.14173	6.53543	6.92913
7	5.00000	5.39370	5.78740	6.18110	6.57480	6.96850
8	5.03937	5.43307	5.82677	6.22047	6.61417	7.00787
9	5.07874	5.47244	5.86614	6.25984	6.65354	7.04724
mm	180	190	200	210	220	230
0	7.08661	7.48031	7.87402	8.26772	8.66142	9.05512
1	7.12598	7.51969	7.91339	8.30709	8.70079	9.09449
2	7.16535	7.55906	7.95276	8.34646	8.74016	9.13386
3	7.20472	7.59843	7.99213	8.38583	8.77953	9.17323
4	7.24409	7.63780	8.03150	8.42520	8.81890	9.21260
5	7.28346	7.67717	8.07087	8.46457	8.85827	9.25197
6	7.32283	7.71654	8.11024	8.50394	8.89764	9.29134
7	7.36220	7.75591	8.14961	8.54331	8.93701	9.33071
8	7.40157	7.79528	8.18898	8.58268	8.97638	9.37008
9	7.44094	7.83465	8.22835	8.62205	9.01575	9.40945



# Inch/Metric Conversion Table

---

## Fractional to Decimal Conversions

Fraction Inch	Decimal Inch	Decimal mm
1/64	0.01563	0.3969
1/32	0.03125	0.7938
3/64	0.04688	1.1906
1/16	0.06250	1.5875
5/64	0.07813	1.9844
3/32	0.09375	2.3813
7/64	0.10938	2.7781
1/8	0.12500	3.1750
9/64	0.14063	3.5719
5/32	0.15625	3.9688
11/64	0.17188	4.3656
3/16	0.18750	4.7625
13/64	0.20313	5.1594
7/32	0.21875	5.5562
15/64	0.23438	5.9531
1/4	0.25000	6.3500
17/64	0.26563	6.7469
9/32	0.28125	7.1438
5/16	0.31250	7.9375
11/32	0.34375	8.7313

Fraction Inch	Decimal Inch	Decimal mm
3/8	0.37500	9.5250
13/32	0.40625	10.3188
7/16	0.43750	11.1125
15/32	0.46875	11.9063
1/2	0.50000	12.7000
17/32	0.53125	13.4937
9/16	0.56250	14.2875
19/32	0.59375	15.0812
5/8	0.62500	15.8750
11/16	0.68750	17.4625
3/4	0.75000	19.0500
13/16	0.81250	20.6375
7/8	0.87500	22.2250
15/16	0.93750	23.8125
1	1.00000	25.4000
1-1/16	1.06250	26.9875
1-1/8	1.12500	28.5750
1-3/16	1.18750	30.1625
1-1/4	1.25000	31.7500
1-5/16	1.31250	33.3375

# NHBB

---

HITECH DIVISION  
175 Jaffrey Road  
Peterborough, New Hampshire 03458

ASTRO DIVISION  
155 Lexington Drive  
Laconia, New Hampshire 03246

PRECISION DIVISION  
CORPORATE HEADQUARTERS  
9727 DeSoto Avenue  
Chatsworth, California 91311

TEL: (603) 924-4100 EAST (818) 993-4100 WEST  
FAX: (603) 924-9302

NHBB EUROPE  
1 Sterling Centre  
Eastern Road  
Bracknell, Berkshire RG12 2PW  
England

TEL: 44 (0) 1344-308888  
FAX: 44 (0) 1344-307777

*Visit us at:* [www.nhbb.com](http://www.nhbb.com)

