

# ROD END BEARINGS – Self-Lubricating

## AS81935/4 Narrow – Male Thread

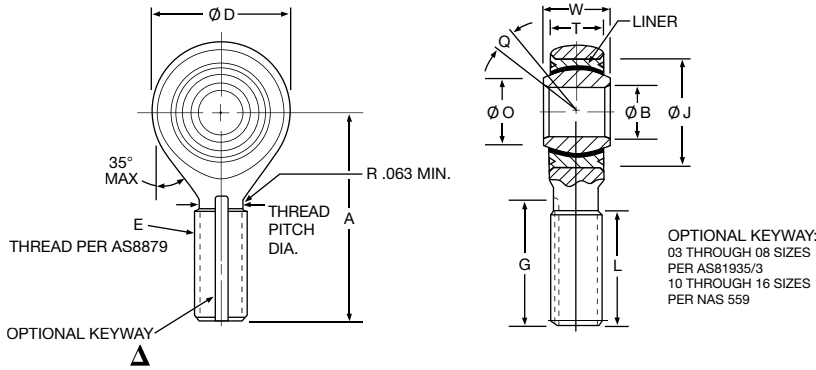

### Notes:

- Bearings listed in the tables are approved for procurement to AS81935.
- Temperature: Operating temperature range per AS81935; -65° to 325°F . Broader temperature capabilities are achievable. Contact NHBB Applications Engineering.

△ For keyway details, refer to the engineering section, pages 68-69.

Part Number	MS Dash No.	(B) Bore Diameter	(D) Head Diameter	(W) Ball Width	(T) Body Width	(O) Shoulder Diameter	Ball Diameter	(A) Ball C/L to End	(E) Thread Size	(L) Complete Thread	(J) Housing I.D.	(G) Keyway Flat	(Q) Mis-alignment
		Inch +.0000 -.0005	Inch +.010 -.010	Inch +.000 -.002	Inch +.005 -.005	Inch Min.	Inch Ref.	Inch +.010 -.010		Inch +.031 -.031	Inch Max.	Inch +.000 -.020	Ref.
<b>M81935/4</b>									UNJF-3A				
ADNE3-382	-03	.1900	.680	.281	.228	.293	.406	1.315	1/4-28	.775	.5625	.896	10°
ADNE4-382	-04	.2500	.827	.343	.260	.364	.500	1.443	1/4-28	.775	.6562	.896	10°
ADNE5-382	-05	.3125	.984	.375	.291	.419	.562	1.948	5/16-24	1.187	.7500	1.308	10°
ADNE6-382	-06	.3750	1.131	.406	.322	.475	.656	2.030	3/8-24	1.187	.8125	1.308	9°
ADNE7-382	-07	.4375	1.294	.437	.353	.530	.718	2.250	7/16-20	1.281	.9062	1.402	8°
ADNE8-382	-08	.5000	1.459	.500	.400	.600	.813	2.544	1/2-20	1.468	1.0000	1.589	8°
ADNE10-382	-10	.6250	1.763	.625	.510	.739	.968	2.832	5/8-18	1.562	1.1875	1.683	8°
ADNE12-382	-12	.7500	2.140	.750	.603	.920	1.187	3.193	3/4-16	1.687	1.4375	1.808	8°
ADNE14-382	-14	.8750	2.372	.875	.713	.980	1.312	3.677	7/8-14	2.000	1.5625	2.121	8°
ADNE16-382	-16	1.0000	2.681	1.000	.807	1.118	1.500	3.968	1-12	2.100	1.7500	2.221	9°

### Aerospace Standard P/N - Narrow

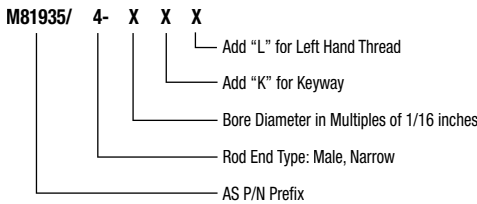

### NHBB P/N - Narrow

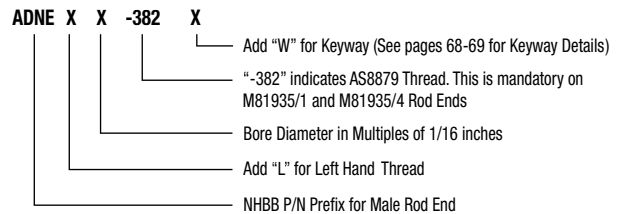

### Materials

Part No.	Ball	Race	Liner	Body
Catalog No.	CRES 440C AMS 5630 Rc55-62	CRES 17-4PH AMS 5643 Rc28-37	PTFE/Fabric Bonded to Race I.D. No Lub. Required	4340 Alloy Steel AMS6415 Rc39-42 H.T. Cadmium Plated††
Catalog No. + CR†	CRES 440C AMS 5630 Rc55-62	CRES 17-4PH AMS 5643 Rc28-37	PTFE/Fabric Bonded to Race I.D. No Lub. Required	CRES 17-4PH AMS 5643 Rc39-44 Passivated

†† Body cadmium plated per AMS-QQ-P-416, Type II, CL. 2 on all surfaces including body bore.  
 † Stainless Steel Series is not available to Aerospace Standard, but may be ordered to NHBB Part Number as indicated. Example: ADNE4CRJ or ADNE4-382CR

### Performance Properties - Narrow

MS Dash No.	No Load Rotational Breakaway Torque	Ultimate Static Radial Load	Axial Static Proof Load	Fatigue Load	Approx. Weight	
						In-lbs.
M81935/4						
ADNE3-382	-03	0.5-6.0	3000	150	1100	.038
ADNE4-382	-04	0.5-6.0	5300	430	1500	.045
ADNE5-382	-05	1.0-15.0	8600	700	2400	.081
ADNE6-382	-06	1.0-15.0	13000	1100	3600	.120
ADNE7-382	-07	1.0-15.0	17800	1400	5000	.172
ADNE8-382	-08	1.0-15.0	24200	2040	6800	.254
ADNE10-382	-10	1.0-15.0	38500	2430	10800	.455
ADNE12-382	-12	1.0-15.0	56600	2940	16000	.774
ADNE14-382	-14	1.0-24.0	77400	3190	21900	1.141
ADNE16-382	-16	1.0-24.0	101400	3570	28600	1.646