



New Hampshire Ball Bearings, Inc.

— *A Minebea Company* —

## Airframe Control Bearings





# NHBB

Airframe Control Bearings

## NHBB's Airframe Control Bearings



Since 1946, New Hampshire Ball Bearings, Inc. (NHBB) has been developing and manufacturing precision ball bearings and customized bearing solutions for the aerospace, defense, dental, medical, and high technology markets. Initially designed to meet rigorous and demanding military requirements, our full line of precision airframe control bearings is now used extensively throughout the commercial aviation industry, enabling engineers to confidently push the limits of airframe design and operation.

Because value, quality, and service are vital to your project's success, we focus on delivering more of all three.

**Value** – We're expanding our Precision Division's manufacturing capacity to produce larger-diameter airframe bearings, and we're acquiring additional military and commercial qualifications to support a greater number of applications. These steps enable us to leverage our Precision Division's volume manufacturing techniques and offer high-quality products at competitive prices with shorter lead times.

**Quality** – Our precision manufacturing operations are tightly controlled by a highly trained quality assurance team that utilizes the latest protocols and technology to ensure that our products meet or exceed all documented specifications.

**Service** – To ensure that you benefit fully from all the advantages our bearings have to offer, we support every sale with fast, reliable customer service that is second to none. From quotes and technical questions to after-sales support, we give you the help you need, when you need it.

We're proud of our people, our products, and our service. If you're not already a customer, we invite you to become one and discover the NHBB difference.



## Preface

### 04 Introduction

- 04 Definition of Airframe Control Bearings
- 04 General Standards for Airframe Control Bearings
- 05 Part Numbering System
- 05 Airframe Bearing Series
- 06 Aerospace Standard (AS) Series
- 06 MS Part Number
- 07 MS Part Numbers and Suffix Codes
- 07 Typical Special Design Numbers

### 08 Products

- 08 KP- (AS27640) / MKP- . . . . . Heavy Duty, Single Row
- 09 KP-A (AS27641) / MKP-A . . . . . Intermediate Duty, Single Row
- 10 KP--B (AS27642) . . . . . Extra Light Duty, Single Row
- 11 MKP--B (AS27642) . . . . . Extra Light Duty, Single Row, Precision
- 12 KP--BS (AS27648) / MKP--BS . . . . . Externally Self-aligning, Single Row, Extra Light Duty
- 13 KSP-, KSP-A (AS27645) / MKSP-, MKSP-A . Self-aligning, Single Row, Light and Heavy Duty
- 14 DSP- (AS27643) / MDSP- . . . . . Self-aligning, Double Row, Heavy Duty
- 15 DPP- (AS27644) / MDPP- . . . . . Double Row, Heavy Duty
- 16 DPP-W . . . . . Double Row, Rigid Type
- 17 B500DD (AS27646) / MB500DD (AS21428) . . . . . Anti-friction, Single Row, Extra Light Duty
- 18 B500 / MB500 . . . . . Torque Tube, Single Row, Extra Light Duty
- 19 B5500WZZ . . . . . Airframe, Torque Tube, Double Row
- 20 DW-K, DW- (AS27647) . . . . . Extra Wide, Double Row, Intermediate Duty
- 21 GDW-K, GDW- (AS27647) . . . . . Extra Wide, Double Row, Intermediate Duty
- 22 MDW-K, MDW- . . . . . Extra Wide, Double Row, Intermediate Duty, Precision
- 23 SSW-AK (AS27649) . . . . . Intermediate Duty, Single Row, Stainless Steel
- 24 K- . . . . . Track Roller, Single Row
- 25 D- . . . . . Track Roller, Double Row
- 26 KP-AK, KP-K, W-AK, P-K, PD-K, P- (AS21443) . . . . . Pulley Bearing, Single and Double Row
- 27 G-, GD- . . . . . Guide Roller, Single and Double Row

### 28 Company Overview

## Airframe Control Bearings

### Airframe Control Bearings

An “airframe” is defined as the basic structure of an aircraft or other flight-related vehicle. As the name implies, airframe control bearings were originally developed for use in airframe flight control systems such as aileron, rudder, and rotor actuators, to name a few. However, due to their precision manufacture and durability, airframe control bearings have also been used in a wide variety of applications outside the aircraft industry, including medical devices, robotics, and materials handling systems – virtually any application requiring a high load capability and oscillatory and/or slow rotation.



### General Standards for Airframe Control Bearings

Historically, most airframe control bearings have been manufactured and inspected in accordance with the United States military procurement standard MIL-B-7949, with its technical content managed by the Airframe Control Bearing Group (ACBG), a consortium of bearing and airframe manufacturers as well as military and academic personnel.

Both the ACBG and MIL-B-7949 were originally overseen by the Department of the Navy-Naval Air Systems Command (NAVAIR), Patuxent River, MD. Products conforming to MIL-B-7949 are listed on the corresponding Qualified Products List (QPL) 7949.

In 1998, the Department of the Navy relinquished control of MIL-B-7949, which was subsequently acquired by the Society of Automotive Engineers (SAE), along with the sponsorship of the ACBG. While affiliated with the SAE, the ACBG has converted MIL-B-7949 to AS7949 and all corresponding Military Standards (MS) to Aerospace Standards (AS)<sup>1</sup>. For administrative purposes, the SAE-ACBG has retained the “MS” part number prefix<sup>2</sup>. Despite these changes, the Department of the Navy still retains control of the QPL.

### Features

Characteristics of airframe control bearings include:

**MATERIALS:** Available in AISI 52100, AISI 440C, or other premium-quality bearing steels.

**MATERIAL COMPATIBILITY:** Polytetrafluoroethylene (PTFE) seals are tolerant of hydraulic fluids, greases, and cleaning solvents.

**LOAD CAPACITY:** Lightweight, compact designs can accommodate heavy radial and/or thrust loads. Static radial and static thrust ratings published for airframe control bearings are based on industry standards (limit load rating =  $KND^2$ ). Static-fracture strength is 1.5 times the limit load rating.

**COMPONENT MINIMIZATION:** Extended inner rings eliminate the need for spacers.

**CORROSION RESISTANCE:** Plated external surfaces minimize galvanic corrosion. Available are cadmium plating per SAE-AMS-QQ-P-416 Type 1, and zinc-nickel per SAE-AMS 2417 Type 2.

**MISALIGNMENT FEATURE:** Misalignment capability up to 10° in either direction (self-aligning types).

*NHBB reserves the right to change specifications and other information included in this catalog without notice. All information, data and dimension tables in this catalog have been carefully compiled and thoroughly checked and are provided on an “as is” basis for informational purposes only. NHBB assumes no responsibility and/or liability whatsoever for any errors or omissions in these materials.*

*All materials in this catalog are protected by copyright laws and may not be reproduced, republished, or otherwise exploited in any manner without the express written permission of NHBB. NHBB names, logos and all related trademarks, tradenames, and other intellectual property (including NHBB part numbers, series numbers, and the like) are the property of NHBB and cannot be used without NHBB's express written permission.*

1. See "Aerospace Standard Series" on page 6 for a complete list of airframe control bearing aerospace standards.

2. See "MS Part Number" on page 6 for an example of the correct "MS" nomenclature.

## Part Numbering System

**EXAMPLE: SSKP10BSD500ZN**

<b>SS</b>	<b>KP10B</b>	<b>SD500</b>	<b>ZN</b>
MATERIAL PREFIX*	BASIC PART NUMBER◆	SPECIAL DESIGN CODE†	PLATING
<b>No Code</b> = AISI 52100 chrome steel <b>SS</b> = AISI 440C stainless steel	<b>KP--B</b> = SERIES▲ <b>10</b> = SIZE DESIGNATOR	<b>SD5XX</b> = Precision Division <b>SD6XX</b> = HiTech Division	<b>No Code</b> = cadmium <b>ZN</b> = zinc-nickel

\* Consult factory for a complete list of material prefixes.

◆ See dimension tables for appropriate Basic Part Numbers.

▲ See table below for a complete list of airframe bearings series.

† Consult factory for a complete list of Special Design Numbers.

## Airframe Bearings Series

SERIES	DESCRIPTION
KP-	Heavy Duty
MKP-	Heavy Duty, Precision
KP-A	Intermediate Duty
MKP-A	Intermediate Duty, Precision
KP--B	Extra Light Duty
MKP--B	Extra Light Duty, Precision
DSP-	Self-aligning, Double Row, Heavy Duty
MDSP-	Self-aligning, Double Row, Heavy Duty, Precision
DPP-	Double Row, Heavy Duty
MDPP-	Double Row, Heavy Duty, Precision
DPP-W	Double Row, Rigid Type
KSP-, KSP-A	Self-aligning, Light and Heavy Duty
MKSP-, MKSP-A	Self-aligning, Light and Heavy Duty, Precision
B500DD	Anti-friction, Extra Light Duty

SERIES	DESCRIPTION
MB500DD	Anti-friction, Extra Light Duty, Precision
B500	Torque Tube, Extra Light Duty
MB500	Torque Tube, Extra Light Duty, Precision
B5500WZZ	Torque Tube, Double Row
DW-K, DW-, GDW-K, GDW-	Extra Wide, Double Row, Intermediate Duty
MDW-K, MDW-	Extra Wide, Double Row, Intermediate Duty, Precision
KP--BS	Externally Self-aligning, Extra Light Duty
MKP--BS	Externally Self-aligning, Extra Light Duty, Precision
SSW-AK	Intermediate Duty, Stainless Steel
KP-AK, KP-K, P-K, PD-K, P-	Pulley Type
K-	Track Roller, Single Row
D-	Track Roller, Double Row
G-, GD-	Guide Roller

## Aerospace Standard (AS) Series/MS Part Number

### Aerospace Standard (AS) Series

The following table contains a list of NHBB bearing series that have a corresponding SAE Aerospace Standard:

SAE	SERIES		DESCRIPTIVE TITLE	PAGE NO.
		NHBB		
AS21428		MB500DD	Bearing, Ball, Airframe, Anti-friction, Extra Light Duty, Precision	17
AS21443		KP-AK, KP-K, W-AK, P-K, PD-K, P-	Bearing, Ball, Airframe, Anti-friction, Pulley	26
AS27640		KP-	Bearing, Ball, Airframe, Anti-friction, Heavy Duty	8
AS27641		KP-A	Bearing, Ball, Airframe, Anti-friction, Intermediate Duty	9
AS27642		KP--B, MKP--B	Bearing, Ball, Airframe, Extra Light Duty	10
AS27643		DSP-	Bearing, Ball, Airframe, Anti-friction, Self-aligning, Double Row, Heavy Duty	14
AS27644		DPP-	Bearing, Ball, Airframe, Anti-friction, Double Row, Heavy Duty	15
AS27645		KSP-, KSP-A	Bearing, Ball, Airframe, Anti-friction, Self-aligning, Light and Heavy Duty	13
AS27646		B500DD	Bearing, Ball, Airframe, Anti-friction, Extra Light Duty	17
AS27647		DW-K, DW-, GDW-K, GDW-	Bearing, Ball, Airframe, Anti-friction, Extra Wide, Double Row, Intermediate Duty	20-21
AS27648		KP--BS	Bearing, Ball, Airframe, Anti-friction, External Self-aligning, Extra Light Duty	12
AS27649		SSW-AK	Bearing, Ball, Airframe, Anti-friction, Intermediate Duty (Stainless Steel)	23

### "MS" Part Number

When ordering bearings in accordance with AS7949, please indicate the correct "MS" part number per the following example:

Aerospace Series: AS27642  
 MS Dash Number: -23  
 MS Part Number: MS27642-23

The "MS" part number is typically marked on the package label. Where applicable, see the appropriate Aerospace Standard for detailed marking nomenclature.

## MS Part Numbers and Suffix Codes/Special Design Numbers

## MS Part Numbers and Suffix Codes

SERIES		CODE AND DESCRIPTION		
NHBB	SAE	SPECIAL FEATURES	RADIAL PLAY •	LUBRICATION
MB5--DD	MS21428			G = MIL-PRF-23827
KP-AK...etc.	MS21443			G = MIL-PRF-23827
KP-	MS27640		R = .0002 TO .0005	G = MIL-PRF-23827
KP-A	MS27641		R = .0002 TO .0005	G = MIL-PRF-23827
KP--B	MS27642			G = MIL-PRF-23827
MKP--B	MS27642*	S=Precision Bore	S = .0001 TO .0005	G = MIL-PRF-23827
DSP-	MS27643		R = .0002 TO .0005	G = MIL-PRF-23827
DPP-	MS27644			G = MIL-PRF-23827
KSP, KSP-A	MS27645		R = .0001 TO .0005	G = MIL-PRF-23827
B5--DD	MS27646			G = MIL-PRF-23827
DW-K, DW-	MS27647		R = .0002 TO .0005	L = MIL-PRF-23827
GDW-K, GDW-	MS27647♦	G=Grease Groove	R = .0002 TO .0005	L = MIL-PRF-23827
KP--BS	MS27648			G = MIL-PRF-23827
SSW-AK	MS27649			G = MIL-PRF-23827

\* 'S' Suffix designates a precision bore tolerance (-16 through -49) plus a reduced radial play.

♦ 'G' Suffix designates a relubrication feature, i.e., a circumferential grease groove plus three or four through-holes in the outer ring O.D.

• "Radial play" is the same as "radial internal clearance."

## Typical Special Design Numbers

NUMBER	DESCRIPTION	AS SUFFIX
None	= Standard lubrication, radial play, etc.*	
SD510/SD610	= MIL-PRF-23827 grease, 80 to 100% full	'G'
SD529/SD629	= Aeroshell Grease 33 (MIL-PRF-23827), 80 to 100% full	'G' or 'L'**
SD530/SD630	= Reduced radial internal clearance	'R' or 'S'***
SD531/SD631	= Reduced radial internal clearance plus MIL-PRF-23827 grease, 80 to 100% full	'RG', 'SG', or 'RL'***

\*Bearings are lubricated with MIL-PRF-81322 grease, 80% minimum fill. For radial play, consult the factory or refer to the AS specifications standards.

\*\*See MS Part Numbers and Suffix Codes above.



KP- (AS27640) / MKP- Series

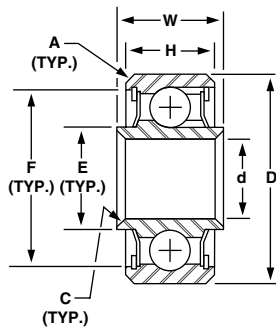

Full ball complement (no retainer)

Notes:

1. Rings and balls are manufactured from premium quality AISI 52100 chrome steel.
2. Operating temperature range: -65 to +250 °F.
3. All bearings include removable PTFE seals, except as noted.
4. Bearings are lubricated with MIL-PRF-81322 grease, 80% minimum fill, unless otherwise specified.
5. External surfaces (except bore) are cadmium plated per AMS-QQ-P-416. All dimensions apply after plating.
6. Custom sizes, materials, tolerances, radial internal clearances, lubrication, plating, etc., are available upon request.
7. See "Airframe Part Numbering System" on page 5 for correct NHBB nomenclature.
8. All dimensions are in inches, unless otherwise specified.

Refer to the Qualifications and Manufacturing Schedule for a current list of the Precision Division's AS7949 qualifications and manufacturing capabilities.

KP- (AS27640) — Qualified to SAE AS7949

NHBB BASIC P/N	MS27640 DASH NO.	BORE d	O.D. D	RING WIDTH		BALL COMPLEMENT		RING SHOULDER DIAMETER		RING CHAMFER X 45°		LOAD RATINGS (LBS.)				APPROX. WEIGHT	MAX. STARTING TORQUE <sup>^</sup>
				OUTER H	INNER W	NO.	DIA.	OUTER F	INNER E	OUTER A	INNER C	STATIC		DYNAMIC RADIAL+ RING ROTATION			
												RADIAL LIMIT	AXIAL LIMIT	INNER	OUTER		
		+0.000 -0.005	+0.000 -0.005	+0.000 -0.005	+0.000 -0.005			REF.	REF.	+0.015 -0.000	+0.015 -0.000					LBS.	OZ.-IN.
KP3L <sup>(1)</sup>	-3A	.1900	.6250	.203	.245	10	1/8	.537	.272	.010	.005	1560	700	1520	1260	.01	1.0
KP3	-3	.1900	.7774	.270	.297	12	1/8	.620	.331	.022	.005	1880	900	1700	1450	.03	1.0
KP4	-4	.2500	.9014	.335	.484	11	5/32	.735	.390	.032	.005	2680	1200	2410	2030	.04	1.0
KP5	-5	.3125	1.2500	.375	.558	9	1/4	1.009	.472	.032	.015	5620	2500	4900	3970	.09	1.0
KP6	-6	.3750	1.4375	.469	.620	10	9/32	1.236	.594	.032	.015	7910	3500	6540	5410	.15	2.0
KP8	-8	.5000	1.6875	.500	.620	10	11/32	1.463	.768	.044	.015	11800	5200	9320	7700	.21	3.0
KP10	-10	.6250	1.9375	.500	.620	10	3/8	1.695	.853	.044	.015	14100	6200	11000	9060	.28	4.0

Radial internal clearance: .0004 to .0010

<sup>(1)</sup> Bonded PTFE seals – KP3L (MS27640-3A) only.

MKP- Precision Series

NHBB BASIC P/N	BORE d	O.D. D	RING WIDTH		BALL COMPLEMENT		RING SHOULDER DIAMETER		RING CHAMFER X 45°		LOAD RATINGS (LBS.)				APPROX. WEIGHT	MAX. STARTING TORQUE <sup>^</sup>
			OUTER H	INNER W	NO.	DIA.	OUTER F	INNER E	OUTER A	INNER C	STATIC		DYNAMIC RADIAL+ RING ROTATION			
											RADIAL LIMIT	AXIAL LIMIT	INNER	OUTER		
	+0.000 -0.003	+0.000 -0.004	+0.000 -0.005	+0.000 -0.0025			REF.	REF.	+0.015 -0.000	+0.015 -0.000					LBS.	OZ.-IN.
MKP3L <sup>(1)</sup>	.1900	.6250	.203	.2450	10	1/8	.537	.272	.010	.005	1560	700	1520	1260	.01	1.0
MKP3	.1900	.7774	.270	.2970	12	1/8	.620	.331	.022	.005	1880	900	1700	1450	.03	1.0
MKP4	.2500	.9014	.335	.4840	11	5/32	.735	.390	.032	.005	2680	1200	2410	2030	.04	1.0
MKP5	.3125	1.2500	.375	.5580	9	1/4	1.009	.472	.032	.015	5620	2500	4900	3970	.09	1.0
MKP6	.3750	1.4375	.469	.6200	10	9/32	1.236	.594	.032	.015	7910	3500	6540	5410	.15	2.0
MKP8	.5000	1.6875	.500	.6200	10	11/32	1.463	.768	.044	.015	11800	5200	9320	7700	.21	3.0
MKP10	.6250	1.9375	.500	.6200	10	3/8	1.695	.853	.044	.015	14100	6200	11000	9060	.28	4.0

Radial internal clearance: .0002 to .0005

<sup>(1)</sup> Bonded PTFE seals – MKP3L only.

+Dynamic radial load ratings are for operation up to 250 °F. Reduce load ratings by 20% for 250 to 350 °F operation. Dynamic radial load ratings are based on an average life of 10,000 complete 90° cycles.

<sup>^</sup>Torque limits are for bearings lubricated with MIL-PRF-81322 grease. For bearings lubricated with MIL-PRF-23827, multiply torque limits by a factor of 1.2.



KP-A (AS27641) / MKP-A Series

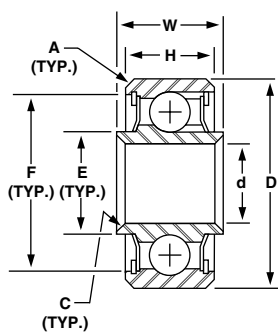

Full ball complement (no retainer)

Notes:

1. Rings and balls are manufactured from premium quality AISI 52100 chrome steel.
2. Operating temperature range: -65 to +250 °F.
3. All bearings include removable PTFE seals.
4. Bearings are lubricated with MIL-PRF-81322 grease, 80% minimum fill, unless otherwise specified.
5. External surfaces (except bore) are cadmium plated per AMS-QQ-P-416. All dimensions apply after plating.
6. Custom sizes, materials, tolerances, radial internal clearances, lubrication, plating, etc., are available upon request.
7. See "Airframe Part Numbering System" on page 5 for correct NHBB nomenclature.
8. All dimensions are in inches, unless otherwise specified.

Refer to the Qualifications and Manufacturing Schedule for a current list of the Precision Division's AS7949 qualifications and manufacturing capabilities.

KP-A (AS27641) — Qualified to SAE AS7949

NHBB BASIC P/N	MS27641 DASH NO.	BORE d	O.D. D	RING WIDTH		BALL COMPLEMENT		RING SHOULDER DIAMETER		RING CHAMFER X 45°		LOAD RATINGS (LBS.)				APPROX. WEIGHT	MAX. STARTING TORQUE <sup>^</sup>
				OUTER H	INNER W	NO.	DIA.	OUTER F	INNER E	OUTER A	INNER C	STATIC		DYNAMIC RADIAL+ RING ROTATION			
												RADIAL	THRUST	INNER	OUTER		
		+0.000 -0.005	+0.000 -0.005	+0.00 -0.05	+0.00 -0.05			REF.	REF.	+0.015 -0.000	+0.015 -0.000	RADIAL LIMIT	AXIAL LIMIT			LBS.	OZ.-IN.
KP3AL	(1)	.1900	.5000	.196	.237	11	3/32	.420	.258	.012	.005	970	430	962	813	.01	1.0
KP3A	-3	.1900	.6250	.234	.297	10	1/8	.531	.297	.016	.005	1560	700	1500	1250	.01	1.0
KP4A	-4	.2500	.7500	.219	.281	12	1/8	.618	.380	.016	.005	1880	900	1690	1450	.02	1.5
KP5A	-5	.3125	.8125	.234	.297	14	1/8	.697	.417	.016	.015	2190	1000	1820	1600	.02	1.5
KP6A	-6	.3750	.8750	.250	.313	16	1/8	.772	.493	.016	.015	2500	1100	1920	1710	.03	2.0
KP8A	-8	.5000	1.1250	.313	.375	16	5/32	.980	.616	.016	.015	3910	1700	2870	2550	.05	2.5
KP10A	-10	.6250	1.3750	.344	.406	14	7/32	1.242	.768	.032	.015	6700	3000	4980	4360	.08	3.0
KP12A	-12	.7500	1.6250	.375	.437	16	15/64	1.434	.919	.032	.015	8790	3900	5980	5320	.13	3.0
KP16A	-16	1.0000	2.0000	.438	.500	19	1/4	1.790	1.238	.032	.015	11900	5200	7070	6400	.22	4.0
KP20A	-20	1.2500	2.2500	.438	.500	22	1/4	1.975	1.540	.032	.015	13800	6100	7400	6810	.26	5.0

Radial internal clearance: .0004 to .0010

(1) KP3AL equivalent not defined.

MKP-A Precision Series

NHBB BASIC P/N	BORE d	O.D. D	RING WIDTH		BALL COMPLEMENT		RING SHOULDER DIAMETER		RING CHAMFER X 45°		LOAD RATINGS (LBS.)				APPROX. WEIGHT	MAX. STARTING TORQUE <sup>^</sup>
			OUTER H	INNER W	NO.	DIA.	OUTER F	INNER E	OUTER A	INNER C	STATIC		DYNAMIC RADIAL+ RING ROTATION			
											RADIAL	THRUST	INNER	OUTER		
	+0.000 -0.003	+0.000 -0.004	+0.00 -0.05	+0.000 -0.025			REF.	REF.	+0.015 -0.000	+0.015 -0.000	RADIAL LIMIT	AXIAL LIMIT			LBS.	OZ.-IN.
MKP3AL	.1900	.5000	.196	.2370	11	3/32	.420	.258	.012	.005	970	430	962	813	.01	1.0
MKP3A	.1900	.6250	.234	.2970	10	1/8	.531	.297	.016	.005	1560	700	1500	1250	.01	1.0
MKP4A	.2500	.7500	.219	.2810	12	1/8	.618	.380	.016	.005	1880	900	1690	1450	.02	1.5
MKP5A	.3125	.8125	.234	.2970	14	1/8	.697	.417	.016	.015	2190	1000	1820	1600	.02	1.5
MKP6A	.3750	.8750	.250	.3130	16	1/8	.772	.493	.016	.015	2500	1100	1920	1710	.03	2.0
MKP8A	.5000	1.1250	.313	.3750	16	5/32	.980	.616	.016	.015	3910	1700	2870	2550	.05	2.5
MKP10A	.6250	1.3750	.344	.4060	14	7/32	1.242	.768	.032	.015	6700	3000	4980	4360	.08	3.0
MKP12A	.7500	1.6250	.375	.4370	16	15/64	1.434	.919	.032	.015	8790	3900	5980	5320	.13	3.0
MKP16A	1.0000	2.0000	.438	.5000	19	1/4	1.790	1.238	.032	.015	11900	5200	7070	6400	.22	4.0
MKP20A	1.2500	2.2500	.438	.5000	22	1/4	1.975	1.540	.032	.015	13800	6100	7400	6810	.26	5.0

Radial internal clearance: .0002 to .0005

+Dynamic radial load ratings are for operation up to 250 °F. Reduce load ratings by 20% for 250 to 350 °F operation. Dynamic radial load ratings are based on an average life of 10,000 complete 90° cycles.

<sup>^</sup>Torque limits are for bearings lubricated with MIL-PRF-81322 grease. For bearings lubricated with MIL-PRF-23827, multiply torque limits by a factor of 1.2.



KP--B Series (AS27642)

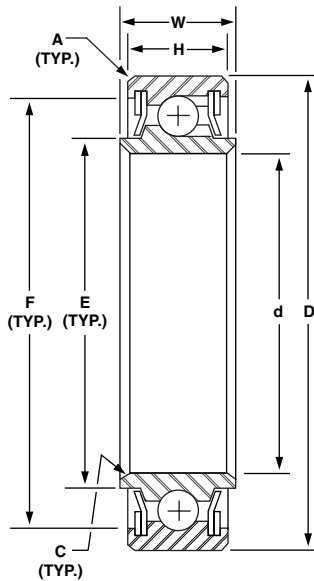

Full ball complement (no retainer)

Notes:

1. Rings and balls are manufactured from premium quality AISI 52100 chrome steel.
2. Operating temperature range: -65 to +250 °F.
3. All bearings include removable PTFE seals.
4. Bearings are lubricated with MIL-PRF-81322 grease, 80% minimum fill, unless otherwise specified.
5. External surfaces (except bore) are cadmium plated per AMS-QQ-P-416. All dimensions apply after plating.
6. Custom sizes, materials, tolerances, radial internal clearances, lubrication, plating, etc., are available upon request.
7. See "Airframe Part Numbering System" on page 5 for correct NHBB nomenclature.
8. All dimensions are in inches, unless otherwise specified.

Refer to the Qualifications and Manufacturing Schedule for a current list of the Precision Division's AS7949 qualifications and manufacturing capabilities.

KP--B (AS27642) — Qualified to SAE AS7949

NHBB BASIC P/N	MS27642 DASH NO.	BORE d	O.D. D	RING WIDTH		BALL COMPLEMENT		RING SHOULDER DIAMETER		RING CHAMFER X 45°		LOAD RATINGS (LBS.)				APPROX. WEIGHT LBS.	MAX. STARTING TORQUE <sup>^</sup> OZ.-IN.
				OUTER H	INNER W	NO.	DIA.	OUTER F	INNER E	OUTER A	INNER C	STATIC		DYNAMIC RADIAL <sup>+</sup> RING ROTATION			
												RADIAL LIMIT	THRUST AXIAL LIMIT	INNER	OUTER		
		+0.000 -0.010	+0.000 -0.010	+0.000 -0.005	+0.000 -0.005			REF.	REF.	+0.015 -0.000	+0.015 -0.000	RADIAL	AXIAL			LBS.	OZ.-IN.
KP16B <sup>(1)</sup>	-16	1.0000 <sup>(3)</sup>	1.7500	.375	.437	23	3/16	1.589	1.189	.024	.024	8085	3600	4260	3960	.14	5.0
KP21B <sup>(1)</sup>	-21	1.3130	2.0625	.375	.437	28	3/16	1.912	1.512	.024	.024	9840	4400	4590	4290	.16	7.0
KP23B <sup>(1)</sup>	-23	1.4380	2.1875	.375	.437	30	3/16	1.988	1.624	.024	.024	10500	4700	4650	4360	.17	9.0
KP25B <sup>(1)</sup>	-25	1.5630	2.3125	.375	.437	32	3/16	2.108	1.743	.024	.024	11300	5000	4680	4420	.19	9.0
KP29B <sup>(1)</sup>	-29	1.8130	2.5625	.375	.437	36	3/16	2.349	1.980	.024	.024	12700	5600	4760	4530	.21	14.0
KP33B <sup>(1)</sup>	-33	2.0630	2.8125	.375	.437	41	3/16	2.647	2.278	.024	.024	14400	6400	4820	4630	.23	14.0
KP37B <sup>(1)</sup>	-37	2.3130	3.0625	.375	.437	45	3/16	2.886	2.516	.024	.024	15800	7000	4880	4690	.26	20.0
KP47B <sup>(1)</sup>	-47	2.9380	3.8750	.469	.531	45	15/64	3.609	3.149	.039	.039	24700	10900	6600	6390	.49	30.0
KP49B <sup>(1)</sup>	-49	3.0630	4.0000	.469	.531	44	1/4	3.785	3.262	.039	.039	27500	12100	8150	7840	.53	32.0
KP52B <sup>(2)</sup>	-52	3.2500	4.1875	.469	.531	46	1/4	3.914	3.444	.039	.039	28700	12600	8210	7880	.65	(4)
KP56B <sup>(2)</sup>	-56	3.5000	4.4375	.469	.531	50	1/4	4.248	3.730	.039	.039	31200	13700	8240	7970	.70	(4)
KP60B <sup>(2)</sup>	-60	3.7500	4.6875	.469	.531	53	1/4	4.505	3.987	.039	.039	33100	14600	8290	8010	.74	(4)
KP64B <sup>(2)</sup>	-64	4.0000	4.9375	.469	.531	56	1/4	4.728	4.246	.039	.039	35000	15400	8350	8100	.78	(4)
KP68B <sup>(2)</sup>	-68	4.2500	5.3125	.531	.593	53	9/32	5.060	4.516	.039	.039	41900	18400	10280	9900	.87	(4)
KP72B <sup>(2)</sup>	-72	4.5000	5.5625	.531	.593	56	9/32	5.322	4.776	.039	.039	44300	19500	10330	10000	.92	(4)
KP76B <sup>(2)</sup>	-76	4.7500	5.8125	.531	.593	59	9/32	5.594	5.045	.039	.039	46700	20500	10350	10050	1.00	(4)
KP80B <sup>(2)</sup>	-80	5.0000	6.0625	.531	.593	61	9/32	5.786	5.242	.039	.039	48200	21200	10360	10090	1.04	(4)
KP84B <sup>(2)</sup>	-84	5.2500	6.3125	.531	.593	64	9/32	6.048	5.504	.039	.039	50600	22300	10420	10120	1.09	(4)

(1) Radial internal clearance: .0003 to .0010  
 (2) Radial internal clearance: .0003 to .0015  
 (3) Bore (d) tolerance: +.0000 / -.0005  
 (4) Consult factory for torque estimate.

+Dynamic radial load ratings are for operation up to 250 °F. Reduce load ratings by 20% for 250 to 350 °F operation. Dynamic radial load ratings are based on an average life of 10,000 complete 90° cycles.

<sup>^</sup>Torque limits are for bearings lubricated with MIL-PRF-81322 grease. For bearings lubricated with MIL-PRF-23827, multiply torque limits by a factor of 1.2.



MKP--B Series (AS27642)

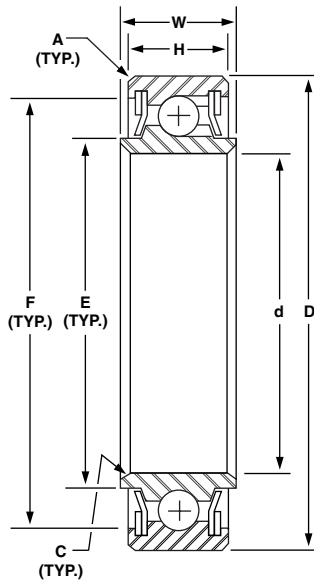

Full ball complement (no retainer)

Notes:

1. Rings and balls are manufactured from premium quality AISI 52100 chrome steel.
2. Operating temperature range: -65 to +250 °F.
3. All bearings include removable PTFE seals.
4. Bearings are lubricated with MIL-PRF-81322 grease, 80% minimum fill, unless otherwise specified.
5. External surfaces (except bore) are cadmium plated per AMS-QQ-P-416. All dimensions apply after plating.
6. Custom sizes, materials, tolerances, radial internal clearances, lubrication, plating, etc., are available upon request.
7. See "Airframe Part Numbering System" on page 5 for correct NHBB nomenclature.
8. All dimensions are in inches, unless otherwise specified.

Refer to the Qualifications and Manufacturing Schedule for a current list of the Precision Division's AS7949 qualifications and manufacturing capabilities.

MKP--B (AS27642) Precision Series — Qualified to SAE AS7949

NHBB BASIC P/N	MS27642-S DASH NO.	BORE d	O.D. D	RING WIDTH		BALL COMPLEMENT		RING SHOULDER DIAMETER		RING CHAMFER X 45°		LOAD RATINGS (LBS.)				APPROX. WEIGHT LBS.	MAX. STARTING TORQUE <sup>^</sup> OZ.-IN.
				OUTER H	INNER W	NO.	DIA.	OUTER F	INNER E	OUTER A	INNER C	STATIC		DYNAMIC RADIAL <sup>+</sup> RING ROTATION			
												RADIAL LIMIT	THRUST LIMIT	INNER	OUTER		
		+0.000 -0.005	+0.000 -0.010	+0.000 -0.005	+0.000 -0.0025			REF.	REF.	+0.015 -0.000	+0.015 -0.000	RADIAL LIMIT	AXIAL LIMIT			LBS.	OZ.-IN.
MKP16B	-16S	1.0000	1.7500 <sup>(2)(3)</sup>	.375	.4370 <sup>(3)</sup>	23	3/16	1.589	1.189	.024	.024	8085	3600	4260	3960	.14	5.0
MKP21B	-21S	1.3125	2.0625	.375	.4370 <sup>(3)</sup>	28	3/16	1.912	1.512	.024	.024	9840	4400	4590	4290	.16	7.0
MKP23B	-23S	1.4375	2.1875	.375	.4370 <sup>(3)</sup>	30	3/16	1.988	1.624	.024	.024	10500	4700	4650	4360	.17	9.0
MKP25B	-25S	1.5625	2.3125	.375	.4370 <sup>(3)</sup>	32	3/16	2.108	1.743	.024	.024	11300	5000	4680	4420	.19	9.0
MKP29B	-29S	1.8125	2.5625	.375	.4370 <sup>(3)</sup>	36	3/16	2.349	1.980	.024	.024	12700	5600	4760	4530	.21	14.0
MKP33B	-33S	2.0625	2.8125	.375	.4370 <sup>(3)</sup>	41	3/16	2.647	2.278	.024	.024	14400	6400	4820	4630	.23	14.0
MKP37B	-37S	2.3125	3.0625	.375	.4370 <sup>(3)</sup>	45	3/16	2.886	2.516	.024	.024	15800	7000	4880	4690	.26	20.0
MKP47B	-47S	2.9375	3.8750	.469	.5310 <sup>(3)</sup>	45	15/64	3.609	3.149	.039	.039	24700	10900	6600	6390	.49	30.0
MKP49B	-49S	3.0625	4.0000	.469	.5310 <sup>(3)</sup>	44	1/4	3.785	3.262	.039	.039	27500	12100	8150	7840	.53	32.0
MKP52B	-52S	3.2500 <sup>(1)</sup>	4.1875	.469	.5310 <sup>(3)</sup>	46	1/4	3.914	3.444	.039	.039	28700	12600	8210	7880	.65	(4)
MKP56B	-56S	3.5000 <sup>(1)</sup>	4.4375	.469	.5310 <sup>(3)</sup>	50	1/4	4.248	3.730	.039	.039	31200	13700	8240	7970	.70	(4)
MKP60B	-60S	3.7500 <sup>(1)</sup>	4.6875	.469	.5310 <sup>(3)</sup>	53	1/4	4.505	3.987	.039	.039	33100	14600	8290	8010	.74	(4)
MKP64B	-64S	4.0000 <sup>(1)</sup>	4.9375	.469	.5310 <sup>(3)</sup>	56	1/4	4.728	4.246	.039	.039	35000	15400	8350	8100	.78	(4)
MKP68B	-68S	4.2500 <sup>(1)</sup>	5.3125	.531	.5930 <sup>(3)</sup>	53	9/32	5.060	4.516	.039	.039	41900	18400	10280	9900	.87	(4)
MKP72B	-72S	4.5000 <sup>(1)</sup>	5.5625	.531	.5930 <sup>(3)</sup>	56	9/32	5.322	4.776	.039	.039	44300	19500	10330	10000	.92	(4)
MKP76B	-76S	4.7500 <sup>(1)</sup>	5.8125	.531	.5930 <sup>(3)</sup>	59	9/32	5.594	5.045	.039	.039	46700	20500	10350	10050	1.00	(4)
MKP80B	-80S	5.0000 <sup>(1)</sup>	6.0625	.531	.5930 <sup>(3)</sup>	61	9/32	5.786	5.242	.039	.039	48200	21200	10360	10090	1.04	(4)
MKP84B	-84S	5.2500 <sup>(1)</sup>	6.3125	.531	.5930 <sup>(3)</sup>	64	9/32	6.048	5.504	.039	.039	50600	22300	10420	10120	1.09	(4)

Radial internal clearance: .0001 to .0005

(1) Bore (d) tolerance: +.0000 / -.0010

(2) O.D. (D) tolerance: +.0000 / -.0005

(3) Indicated parameters exceed MS27642-S requirements.

(4) Consult factory for torque estimate.

+Dynamic radial load ratings are for operation up to 250 °F. Reduce load ratings by 20% for 250 to 350 °F operation. Dynamic radial load ratings are based on an average life of 10,000 complete 90° cycles.

<sup>^</sup>Torque limits are for bearings lubricated with MIL-PRF-81322 grease. For bearings lubricated with MIL-PRF-23827, multiply torque limits by a factor of 1.2.



KP--BS (AS27648) / MKP--BS Series

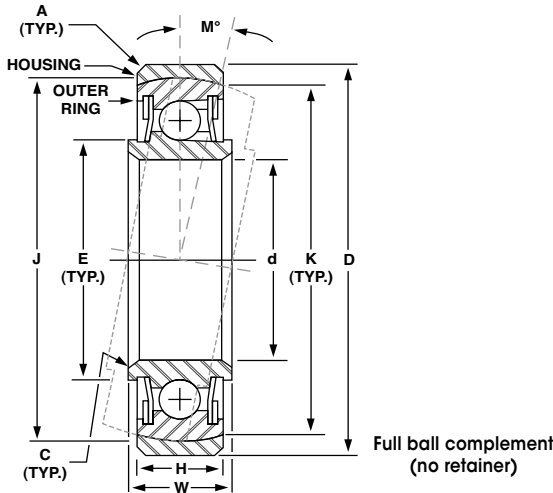

Notes:

1. Rings and balls are manufactured from premium quality AISI 52100 chrome steel.
2. Operating temperature range: -65 to +250 °F.
3. All bearings include removable PTFE seals.
4. Bearings are lubricated with MIL-PRF-81322 grease, 80% minimum fill, unless otherwise specified.
5. External surfaces (except bore) are cadmium plated per AMS-QQ-P-416. All dimensions apply after plating.
6. Custom sizes, materials, tolerances, radial internal clearances, lubrication, plating, etc., are available upon request.
7. See "Airframe Part Numbering System" on page 5 for correct NHBB nomenclature.
8. All dimensions are in inches, unless otherwise specified.

Refer to the Qualifications and Manufacturing Schedule for a current list of the Precision Division's AS7949 qualifications and manufacturing capabilities.

KP--BS (AS27648) — Qualified to SAE AS7949

NHBB BASIC P/N	MS27648 DASH NO.	BORE d	O.D. D	RING WIDTH		MIS-ALIGNMENT ANGLE M°	SPHERICAL DIA. J	BALL COMPLEMENT		RING SHOULDER DIAMETER		RING CHAMFER X 45°		LOAD RATINGS (LBS.)				APPROX. WEIGHT	MAX. STARTING TORQUE <sup>^</sup>
				OUTER H*	INNER W			NO.	DIA.	INNER E	HOUSING K†	OUTER A	INNER C	STATIC		DYNAMIC RADIAL+ RING ROTATION			
														RADIAL LIMIT	AXIAL LIMIT	INNER	OUTER		
		+0.000 -0.0010	+0.000 -0.0010	+0.000 -0.005	+0.000 -0.005		REF.			REF.	REF.	+0.015 -0.000	+0.015 -0.000	RADIAL LIMIT	AXIAL LIMIT			LBS.	OZ.-IN.
KP16BS	-16	1.0000 <sup>(1)</sup>	1.9375	.375	.437	±7.42	1.742	23	3/16	1.186	1.724	.024	.024	8085	1600	4260	3960	.18	5.0
KP21BS	-21	1.3130	2.2500	.375	.437	±6.50	2.054	28	3/16	1.509	2.021	.024	.024	9840	2000	4590	4290	.20	7.0
KP23BS	-23	1.4380	2.3750	.375	.437	±6.00	2.179	30	3/16	1.621	2.168	.024	.024	10500	2200	4650	4360	.22	9.0
KP25BS	-25	1.5630	2.5000	.375	.437	±5.75	2.307	32	3/16	1.740	2.295	.024	.024	11300	2300	4680	4420	.25	9.0
KP29BS	-29	1.8130	2.7500	.375	.437	±5.00	2.554	36	3/16	1.980	2.548	.024	.024	12700	2600	4760	4530	.27	14.0
KP33BS	-33	2.0630	3.0000	.375	.437	±5.00	2.804	41	3/16	2.278	2.799	.024	.024	14400	2900	4820	4630	.30	14.0
KP37BS	-37	2.3130	3.2500	.375	.437	±4.50	3.054	45	3/16	2.516	3.051	.024	.024	15800	3200	4880	4690	.33	20.0
KP47BS	-47	2.9380	4.1250	.469	.531	±4.50	3.867	45	15/64	3.149	3.861	.039	.039	24700	5000	6600	6390	.64	30.0
KP48BS	-48	3.0000	4.2500	.469	.531	±4.00	3.991	44	1/4	3.262	3.986	.039	.039	27500	5500	8150	7840	.69	30.0
KP49BS	-49	3.0630	4.2500	.469	.531	±4.00	3.991	44	1/4	3.262	3.986	.039	.039	27500	5500	8150	7840	.69	32.0

Radial internal clearance: .0003 to .0010 (Does not include the radial looseness between the self-aligning outer ring and the housing.)

<sup>(1)</sup> Bore (d) tolerance: +.0000 / -.0005

MKP--BS Precision Series

NHBB BASIC P/N	BORE d	O.D. D	RING WIDTH		MIS-ALIGNMENT ANGLE M°	SPHERICAL DIA. J	BALL COMPLEMENT		RING SHOULDER DIAMETER		RING CHAMFER X 45°		LOAD RATINGS (LBS.)				APPROX. WEIGHT	MAX. STARTING TORQUE <sup>^</sup>
			OUTER H*	INNER W			NO.	DIA.	INNER E	HOUSING K†	OUTER A	INNER C	STATIC		DYNAMIC RADIAL+ RING ROTATION			
													RADIAL LIMIT	AXIAL LIMIT	INNER	OUTER		
	+0.000 -0.0005	+0.000 -0.0010	+0.000 -0.005	+0.000 -0.0025		REF.			REF.	REF.	+0.015 -0.000	+0.015 -0.000	RADIAL LIMIT	AXIAL LIMIT			LBS.	OZ.-IN.
MKP16BS	1.0000	1.9375	.375	.4370	±7.42	1.742	23	3/16	1.186	1.724	.024	.024	8085	1600	4260	3960	.18	5.0
MKP21BS	1.3125	2.2500	.375	.4370	±6.50	2.054	28	3/16	1.509	2.021	.024	.024	9840	2000	4590	4290	.20	7.0
MKP23BS	1.4375	2.3750	.375	.4370	±6.00	2.179	30	3/16	1.621	2.168	.024	.024	10500	2200	4650	4360	.22	9.0
MKP25BS	1.5625	2.5000	.375	.4370	±5.75	2.307	32	3/16	1.740	2.295	.024	.024	11300	2300	4680	4420	.25	9.0
MKP29BS	1.8125	2.7500	.375	.4370	±5.00	2.554	36	3/16	1.980	2.548	.024	.024	12700	2600	4760	4530	.27	14.0
MKP33BS	2.0625	3.0000	.375	.4370	±5.00	2.804	41	3/16	2.278	2.799	.024	.024	14400	2900	4820	4630	.30	14.0
MKP37BS	2.3125	3.2500	.375	.4370	±4.50	3.054	45	3/16	2.516	3.051	.024	.024	15800	3200	4880	4690	.33	20.0
MKP47BS	2.9375	4.1250	.469	.5310	±4.50	3.867	45	15/64	3.149	3.861	.039	.039	24700	5000	6600	6390	.64	30.0
MKP48BS	3.0000	4.2500	.469	.5310	±4.00	3.991	44	1/4	3.262	3.986	.039	.039	27500	5500	8150	7840	.69	30.0
MKP49BS	3.0625	4.2500	.469	.5310	±4.00	3.991	44	1/4	3.262	3.986	.039	.039	27500	5500	8150	7840	.69	32.0

Radial internal clearance: .0001 to .0005 (Does not include the radial looseness between the self-aligning outer ring and the housing.)

\*Housing (outermost ring) width same as outer ring.

†Housing (outermost ring) I.D. chamfer-face breakout diameter. For design reference only. When installed in the application, the misalignment angle should not exceed the stated limiting values in either direction.

+Dynamic radial load ratings are for operation up to 250 °F. Reduce load ratings by 20% for 250 to 350 °F operation. Dynamic radial load ratings are based on an average life of 10,000 complete 90° cycles.

<sup>^</sup>Torque limits are for bearings lubricated with MIL-PRF-81322 grease. For bearings lubricated with MIL-PRF-23827, multiply torque limits by a factor of 1.2.



KSP-, KSP-A (AS27645) / MKSP-, MKSP-A Series

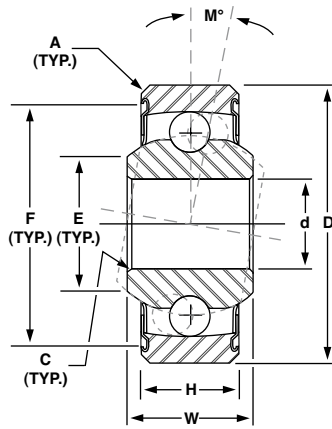

Full ball complement (no retainer)

Notes:

1. Rings and balls are manufactured from premium quality AISI 52100 chrome steel.
2. Operating temperature range: -65 to +250 °F.
3. All bearings include nonremovable PTFE seals.
4. Bearings are lubricated with MIL-PRF-81322 grease, 80% minimum fill, unless otherwise specified.
5. External surfaces (except bore) are cadmium plated per AMS-QQ-P-416. All dimensions apply after plating.
6. Custom sizes, materials, tolerances, radial internal clearances, lubrication, plating, etc., are available upon request.
7. See "Airframe Part Numbering System" on page 5 for correct NHBB nomenclature.
8. All dimensions are in inches, unless otherwise specified.

Refer to the Qualifications and Manufacturing Schedule for a current list of the Precision Division's AS7949 qualifications and manufacturing capabilities.

KSP-, KSP-A (AS27645) — Qualified to SAE AS7949

NHBB BASIC P/N	MS27645 DASH NO.	BORE d	O.D. D	RING WIDTH		MIS-ALIGNMENT ANGLE† M°	BALL COMPLEMENT		RING SHOULDER DIAMETER		RING CHAMFER X 45°		LOAD RATINGS (LBS.)				APPROX. WEIGHT	MAX. STARTING TORQUE^	MAX. AXIAL INTERNAL CLEARANCE	MIN. SEAL BREAKOUT TORQUE
				OUTER H	INNER W		NO.	DIA.	OUTER F	INNER E	OUTER A	INNER C	STATIC		DYNAMIC RADIAL+ RING ROTATION					
													RADIAL	THRUST	INNER	OUTER				
		+0.0000 -0.0005	+0.0000 -0.0005	+0.000 -0.005	+0.000 -0.005				REF.	REF.	+0.015 -0.000	+0.015 -0.000	RADIAL LIMIT	AXIAL LIMIT			LBS.	OZ.-IN.		LBS.-IN.
KSP3L	-3A	.1900	.6250	.203	.245	±10	13	3/32	.549	.278	.016	.005	550	100	550	480	.01	1.0	.023	4.0
KSP4A	-4A	.2500	.7500	.219	.281	±8	12	1/8	.636	.329	.016	.005	900	200	900	770	.01	1.0	.025	6.0
KSP5A	-5A	.3125	.8125	.234	.297	±8	14	.122	.712	.388	.016	.015	1000	200	950	815	.02	2.0	.028	10.0
KSP6A	-6A	.3750	.8750	.250	.313	±8	15	1/8	.763	.463	.016	.016	1120	200	1120	990	.02	3.0	.030	8.0
KSP3	-3	.1900	.7774	.270	.297	±10	12	1/8	.656	.314	.022	.005	900	200	900	770	.03	1.0	.023	6.0
KSP4	-4	.2500	.9014	.335	.484	±10	13	9/64	.756	.399	.032	.005	1410	300	1230	1230	.04	1.0	.025	5.0
KSP5	-5	.3125	1.2500	.375	.558	±10	13	3/16	1.089	.569	.032	.015	2190	300	2190	1890	.10	2.0	.028	16.0
KSP6	-6	.3750	1.4375	.469	.620	±10	13	7/32	1.185	.614	.032	.015	2980	400	2980	2580	.15	3.0	.030	18.0
KSP8	-8	.5000	1.6875	.500	.620	±10	16	7/32	1.418	.811	.044	.015	3670	500	3670	3290	.23	4.0	.032	20.0
KSP10	-10	.6250	1.9375	.625	.813	±10	14	9/32	1.647	.925	.044	.015	5320	600	4980	4360	.37	6.0	.034	25.0

Radial internal clearance: .0000 to .0010

MKSP-, MKSP-A Precision Series

NHBB BASIC P/N	BORE d	O.D. D	RING WIDTH		MIS-ALIGNMENT ANGLE† M°	BALL COMPLEMENT		RING SHOULDER DIAMETER		RING CHAMFER X 45°		LOAD RATINGS (LBS.)				APPROX. WEIGHT	MAX. STARTING TORQUE^	MAX. AXIAL INTERNAL CLEARANCE	MIN. SEAL BREAKOUT TORQUE
			OUTER H	INNER W		NO.	DIA.	OUTER F	INNER E	OUTER A	INNER C	STATIC		DYNAMIC RADIAL+ RING ROTATION					
												RADIAL	THRUST	INNER	OUTER				
	+0.0000 -0.0003	+0.0000 -0.0004	+0.000 -0.005	+0.0000 -0.0025				REF.	REF.	+0.015 -0.000	+0.015 -0.000	RADIAL LIMIT	AXIAL LIMIT			LBS.	OZ.-IN.		LBS.-IN.
MKSP3L	.1900	.6250	.203	.2450	±10	13	3/32	.549	.278	.016	.005	550	100	550	480	.01	1.0	.023	4.0
MKSP4A	.2500	.7500	.219	.2810	±8	12	1/8	.636	.329	.016	.005	900	200	900	770	.01	1.0	.025	6.0
MKSP5A	.3125	.8125	.234	.2970	±8	14	.122	.712	.388	.016	.015	1000	200	950	815	.02	2.0	.028	10.0
MKSP6A	.3750	.8750	.250	.3130	±8	15	1/8	.763	.463	.016	.016	1120	200	1120	990	.02	3.0	.030	8.0
MKSP3	.1900	.7774	.270	.2970	±10	12	1/8	.656	.314	.022	.005	900	200	900	770	.03	1.0	.023	6.0
MKSP4	.2500	.9014	.335	.4840	±10	13	9/64	.756	.399	.032	.005	1410	300	1230	1230	.04	1.0	.025	5.0
MKSP5	.3125	1.2500	.375	.5580	±10	13	3/16	1.089	.569	.032	.015	2190	300	2190	1890	.10	2.0	.028	16.0
MKSP6	.3750	1.4375	.469	.6200	±10	13	7/32	1.185	.614	.032	.015	2980	400	2980	2580	.15	3.0	.030	18.0
MKSP8	.5000	1.6875	.500	.6200	±10	16	7/32	1.418	.811	.044	.015	3670	500	3670	3290	.23	4.0	.032	20.0
MKSP10	.6250	1.9375	.625	.8130	±10	14	9/32	1.647	.925	.044	.015	5320	600	4980	4360	.37	6.0	.034	25.0

Radial internal clearance: .0001 to .0005

†Maximum misalignment angle the bearing can accommodate in either direction.

+Dynamic radial load ratings are for operation up to 250 °F. Reduce load ratings by 20% for 250 to 350 °F operation. Dynamic radial load ratings are based on an average life of 10,000 complete 90° cycles.

^Torque limits are for bearings lubricated with MIL-PRF-81322 grease. For bearings lubricated with MIL-PRF-23827, multiply torque limits by a factor of 1.2.

\*Minimum torque required to dislodge seals.



DSP- (AS27643) / MDSP- Series

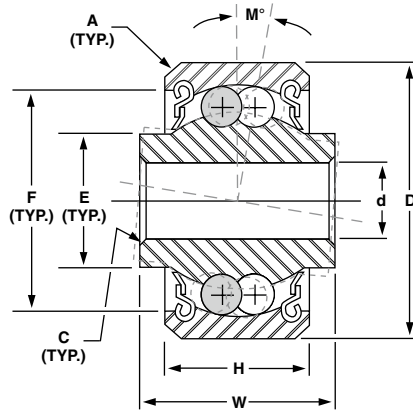

Full ball complement (no retainers)

Notes:

1. Rings and balls are manufactured from premium quality AISI 52100 chrome steel.
2. Operating temperature range: -65 to +250 °F.
3. All bearings include removable PTFE seals.
4. Bearings are lubricated with MIL-PRF-81322 grease, 80% minimum fill, unless otherwise specified.
5. External surfaces (except bore) are cadmium plated per AMS-QQ-P416. All dimensions apply after plating.
6. Custom sizes, materials, tolerances, radial internal clearances, lubrication, plating, etc., are available upon request.
7. See "Airframe Part Numbering System" on page 5 for correct NHBB nomenclature.
8. All dimensions are in inches, unless otherwise specified.

Refer to the Qualifications and Manufacturing Schedule for a current list of the Precision Division's AS7949 qualifications and manufacturing capabilities.

DSP- (AS27643) — Qualified to SAE AS7949

NHBB BASIC P/N	MS27643 DASH NO.	BORE d	O.D. D	RING WIDTH		MIS-ALIGNMENT ANGLE† M°	BALL COMPLEMENT		RING SHOULDER DIAMETER		RING CHAMFER X 45°		LOAD RATINGS (LBS.)				APPROX. WEIGHT	MAX. STARTING TORQUE*	MIN. SEAL BREAKOUT TORQUE*
				OUTER H	INNER W		NO.	DIA.	OUTER F	INNER E	OUTER A	INNER C	STATIC		DYNAMIC RADIAL+ RING ROTATION				
													RADIAL LIMIT	AXIAL LIMIT	INNER	OUTER			
		+0.0000 -0.0010	+0.0000 -0.0010	+0.000 -0.005	+0.000 -0.005				REF.	REF.	+0.015 -0.000	+0.015 -0.000	RADIAL LIMIT	AXIAL LIMIT			LBS.	OZ.-IN.	LBS.-IN.
DSP3	-3	.1900	.7774	.392	.500	±10	24	1/8	.611	.307	.022	.005	1420	200	1420	1220	.04	1.0	8.0
DSP4	-4	.2500	.9014	.464	.687	±10	30	1/8	.740	.432	.032	.005	1780	300	1780	1600	.06	1.0	12.0
DSP5	-5	.3125	1.2500	.656	.812	±10	28	3/16	1.004	.515	.032	.015	3740	600	3740	3300	.16	3.0	28.0
DSP6	-6	.3750	1.4375	.750	.937	±10	28	7/32	1.169	.567	.032	.015	5100	800	4980	4370	.24	4.0	45.0
DSP8	-8	.5000	1.6875	.812	1.000	±10	30	1/4	1.399	.776	.044	.015	7120	1000	6340	5570	.36	5.0	60.0
DSP10	-10	.6250	1.9375	.937	1.125	±10	30	9/32	1.590	.872	.044	.015	9000	1300	7780	6860	.53	6.0	78.0

Radial internal clearance: .0000 to .0010

MDSP- Precision Series

NHBB BASIC P/N	BORE d	O.D. D	RING WIDTH		MIS-ALIGNMENT ANGLE† M°	BALL COMPLEMENT		RING SHOULDER DIAMETER		RING CHAMFER X 45°		LOAD RATINGS (LBS.)				APPROX. WEIGHT	MAX. STARTING TORQUE*	MIN. SEAL BREAKOUT TORQUE*	
			OUTER H	INNER W		NO.	DIA.	OUTER F	INNER E	OUTER A	INNER C	STATIC		DYNAMIC RADIAL+ RING ROTATION					
												RADIAL LIMIT	AXIAL LIMIT	INNER	OUTER				
		+0.0000 -0.0003	+0.0000 -0.0004	+0.000 -0.005	+0.0000 -0.0025				REF.	REF.	+0.015 -0.000	+0.015 -0.000	RADIAL LIMIT	AXIAL LIMIT			LBS.	OZ.-IN.	LBS.-IN.
MDSP3	.1900	.7774	.392	.5000	±10	24	1/8	.611	.307	.022	.005	1420	200	1420	1220	.04	1.0	8.0	
MDSP4	.2500	.9014	.464	.6870	±10	30	1/8	.740	.432	.032	.005	1780	300	1780	1600	.06	1.0	12.0	
MDSP5	.3125	1.2500	.656	.8120	±10	28	3/16	1.004	.515	.032	.015	3740	600	3740	3300	.16	3.0	28.0	
MDSP6	.3750	1.4375	.750	.9370	±10	28	7/32	1.169	.567	.032	.015	5100	800	4980	4370	.24	4.0	45.0	
MDSP8	.5000	1.6875	.812	1.0000	±10	30	1/4	1.399	.776	.044	.015	7120	1000	6340	5570	.36	5.0	60.0	
MDSP10	.6250	1.9375	.937	1.1250	±10	30	9/32	1.590	.872	.044	.015	9000	1300	7780	6860	.53	6.0	78.0	

Radial internal clearance: .0002 to .0005

†Maximum misalignment angle the bearing can accommodate in either direction.

+Dynamic radial load ratings are for operation up to 250 °F. Reduce load ratings by 20% for 250 to 350 °F operation. Dynamic radial load ratings are based on an average life of 10,000 complete 90° cycles.

\*Torque limits are for bearings lubricated with MIL-PRF-81322 grease. For bearings lubricated with MIL-PRF-23827, multiply torque limits by a factor of 1.2.

\*Minimum torque required to dislodge seals.



DPP- (AS27644) / MDPP- Series

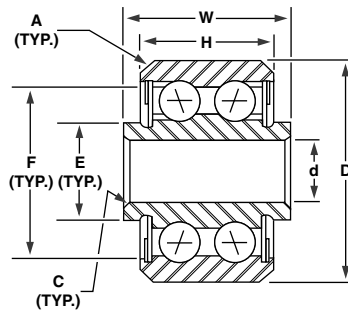

Full ball complement (no retainers)

Notes:

1. Rings and balls are manufactured from premium quality AISI 52100 chrome steel.
2. Operating temperature range: -65 to +250 °F.
3. All bearings include nonremovable PTFE seals.
4. Bearings are lubricated with MIL-PRF-81322 grease, 80% minimum fill, unless otherwise specified.
5. Contact angles are divergent (‘\ /’).
6. External surfaces (except bore) are cadmium plated per AMS-QQ-P-416. All dimensions apply after plating.
7. Custom sizes, materials, tolerances, radial internal clearances, lubrication, plating, etc., are available upon request.
8. See “Airframe Part Numbering System” on page 5 for correct NHBB nomenclature.
9. All dimensions are in inches, unless otherwise specified.

Refer to the Qualifications and Manufacturing Schedule for a current list of the Precision Division’s AS7949 qualifications and manufacturing capabilities.

DPP- (AS27644) — Qualified to SAE AS7949

NHBB BASIC P/N	MS27644 DASH NO.	BORE d	O.D. D	RING WIDTH		BALL COMPLEMENT		RING SHOULDER DIAMETER		RING CHAMFER X 45°		LOAD RATINGS (LBS.)				MAX. AXIAL PLAY	APPROX. WEIGHT	MAX. STARTING TORQUE <sup>^</sup>
				OUTER H	INNER W	NO.	DIA.	OUTER F	INNER E	OUTER A	INNER C	STATIC		DYNAMIC RADIAL <sup>+</sup> RING ROTATION				
												RADIAL LIMIT	THRUST LIMIT	INNER	OUTER			
		+0.000 -0.005	+0.000 -0.005	+0.000 -0.005	+0.000 -0.005			REF.	REF.	+0.015 -0.000	+0.015 -0.000	RADIAL LIMIT	AXIAL LIMIT			LBS.	OZ.-IN.	
DPP3	-3	.1900	.7774	.473	.495	20	5/32	.645	.302	.018	.005	2950	1700	2950	2830	.005	.04	1.0
DPP4	-4	.2500	.9014	.491	.620	22	5/32	.715	.411	.032	.005	5370	1800	3550	3020	.006	.06	1.0
DPP5	-5	.3125	1.2500	.687	.745	22	15/64	1.069	.469	.032	.015	11000	4000	7360	6250	.006	.17	1.5
DPP6	-6	.3750	1.4375	.794	.870	20	9/32	1.222	.551	.032	.015	15760	5300	9690	8120	.006	.26	2.0
DPP8	-8	.5000	1.6875	.856	.932	20	11/32	1.473	.733	.044	.015	23600	7800	14100	11600	.007	.38	3.0
DPP10	-10	.6250	1.9375	.920	.995	24	11/32	1.686	.891	.044	.015	28400	9400	15300	13100	.007	.53	4.5

Radial internal clearance: .0004 to .0010

MDPP- Precision Series

NHBB BASIC P/N	BORE d	O.D. D	RING WIDTH		BALL COMPLEMENT		RING SHOULDER DIAMETER		RING CHAMFER X 45°		LOAD RATINGS (LBS.)				MAX. AXIAL PLAY	APPROX. WEIGHT	MAX. STARTING TORQUE <sup>^</sup>
			OUTER H	INNER W	NO.	DIA.	OUTER F	INNER E	OUTER A	INNER C	STATIC		DYNAMIC RADIAL <sup>+</sup> RING ROTATION				
											RADIAL LIMIT	THRUST LIMIT	INNER	OUTER			
	+0.000 -0.003	+0.000 -0.004	+0.000 -0.005	+0.000 -0.0025			REF.	REF.	+0.015 -0.000	+0.015 -0.000	RADIAL LIMIT	AXIAL LIMIT			LBS.	OZ.-IN.	
MDPP3	.1900	.7774	.473	.4950	20	5/32	.645	.302	.018	.005	2950	1700	2950	2830	.003	.04	1.0
MDPP4	.2500	.9014	.491	.6200	22	5/32	.715	.411	.032	.005	5370	1800	3550	3020	.003	.06	1.0
MDPP5	.3125	1.2500	.687	.7450	22	15/64	1.069	.469	.032	.015	11000	4000	7360	6250	.003	.17	1.5
MDPP6	.3750	1.4375	.794	.8700	20	9/32	1.222	.551	.032	.015	15760	5300	9690	8120	.003	.26	2.0
MDPP8	.5000	1.6875	.856	.9320	20	11/32	1.473	.733	.044	.015	23600	7800	14100	11600	.003	.38	3.0
MDPP10	.6250	1.9375	.920	.9950	24	11/32	1.686	.891	.044	.015	28400	9400	15300	13100	.003	.53	4.5

Radial internal clearance: .0002 to .0005

<sup>+</sup>Dynamic radial load ratings are for operation up to 250 °F. Reduce load ratings by 20% for 250 to 350 °F operation. Dynamic radial load ratings are based on an average life of 10,000 complete 90° cycles.

<sup>^</sup>Torque limits are for bearings lubricated with MIL-PRF-81322 grease. For bearings lubricated with MIL-PRF-23827, multiply torque limits by a factor of 1.2.



## DPP-W Series

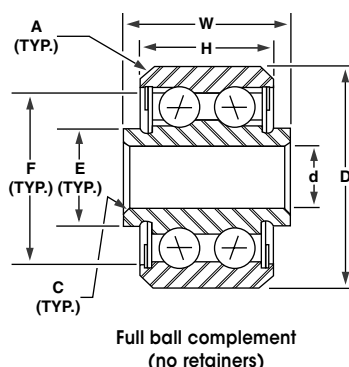

### Notes:

1. Rings and balls are manufactured from premium quality AISI 52100 chrome steel.
2. Operating temperature range: -65 to +250 °F.
3. All bearings include removable PTFE seals.
4. Bearings are lubricated with MIL-PRF-81322 grease, 80% minimum fill, unless otherwise specified.
5. Contact angles are convergent (/\).
6. External surfaces (except bore) are cadmium plated per AMS-QQ-P-416. All dimensions apply after plating.
7. Custom sizes, materials, tolerances, radial internal clearances, lubrication, plating, etc., are available upon request.
8. See "Airframe Part Numbering System" on page 5 for correct NHBB nomenclature.
9. All dimensions are in inches, unless otherwise specified.

*Refer to the Qualifications and Manufacturing Schedule for a current list of the Precision Division's AS7949 qualifications and manufacturing capabilities.*

## DPP-W

NHBB BASIC P/N	BORE d	O.D. D	RING WIDTH		BALL COMPLEMENT		RING SHOULDER DIAMETER		RING CHAMFER X 45°		LOAD RATINGS (LBS.)				MAX. AXIAL PLAY	APPROX. WEIGHT LBS.	MAX. STARTING TORQUE <sup>^</sup> OZ.-IN.
			OUTER H	INNER W	NO.	DIA.	OUTER F	INNER E	STATIC		DYNAMIC RADIAL* RING ROTATION						
									RADIAL LIMIT	THRUST LIMIT	INNER	OUTER					
	+0.0000 -0.0005	+0.0000 -0.0005	+0.000 -0.005	+0.000 -0.005			REF.	REF.	+0.015 -0.000	+0.015 -0.000	RADIAL LIMIT	AXIAL LIMIT					
DPP3W	.1900	.7774	.473	.495	20	5/32	.645	.302	.018	.005	2950	1700	2950	2830	.005	.04	1.0
DPP4W	.2500	.9014	.491	.620	22	5/32	.715	.411	.032	.005	5370	1800	3550	3020	.006	.06	1.0
DPP5W	.3125	1.2500	.687	.745	22	15/64	1.069	.469	.032	.015	11000	4000	7360	6250	.006	.17	1.5
DPP6W	.3750	1.4375	.794	.870	20	9/32	1.222	.551	.032	.015	15760	5300	9690	8120	.006	.26	2.0
DPP8W	.5000	1.6875	.856	.932	20	11/32	1.473	.733	.044	.015	23600	7800	14100	11600	.007	.38	3.0
DPP10W	.6250	1.9375	.920	.995	24	11/32	1.686	.891	.044	.015	28400	9400	15300	13100	.007	.53	4.5

Radial internal clearance: .0004 to .0010

+Dynamic radial load ratings are for operation up to 250 °F. Reduce load ratings by 20% for 250 to 350 °F operation. Dynamic radial load ratings are based on an average life of 10,000 complete 90° cycles.

<sup>^</sup>Torque limits are for bearings lubricated with MIL-PRF-81322 grease. For bearings lubricated with MIL-PRF-23827, multiply torque limits by a factor of 1.2.



**B500DD (AS27646) / MB500DD (AS21428) Series**

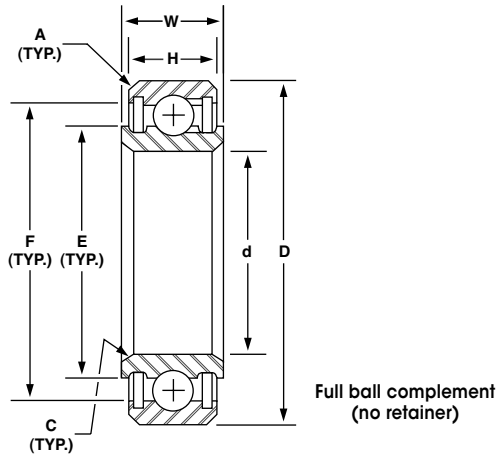

**Notes:**

1. Rings and balls are manufactured from premium quality AISI 52100 chrome steel.
2. Operating temperature range: -65 to +250 °F.
3. All bearings include nonremovable PTFE seals.
4. Bearings are lubricated with MIL-PRF-81322 grease, 80% minimum fill, unless otherwise specified.
5. External surfaces (except bore) are cadmium plated per AMS-QQ-P-416. All dimensions apply after plating.
6. Custom sizes, materials, tolerances, radial internal clearances, lubrication, plating, etc., are available upon request.
7. See "Airframe Part Numbering System" on page 5 for correct NHBB nomenclature.
8. All dimensions are in inches, unless otherwise specified.
9. B500DD/MB500DD series are dimensionally interchangeable with B500/MB500 series (applies to bore, O.D., and width).

Refer to the Qualifications and Manufacturing Schedule for a current list of the Precision Division's AS7949 qualifications and manufacturing capabilities.

**B500DD (AS27646) — Qualified to SAE AS7949**

NHBB BASIC P/N	MS27646 DASH NO.	BORE d	O.D. D	RING WIDTH		BALL COMPLEMENT		RING SHOULDER DIAMETER		RING CHAMFER X 45°		LOAD RATINGS (LBS.)				APPROX. WEIGHT	MAX. STARTING TORQUE <sup>^</sup>
				OUTER H	INNER W	NO.	DIA.	OUTER F	INNER E	OUTER A	INNER C	STATIC		DYNAMIC RADIAL* RING ROTATION			
												RADIAL LIMIT	AXIAL LIMIT	INNER	OUTER		
		+0.007 -0.007	+0.000 -0.010	+0.00 -0.05	+0.00 -0.05			REF.	REF.	+0.015 -0.000	+0.015 -0.000	RADIAL LIMIT	AXIAL LIMIT			LBS.	OZ.-IN.
B538DD	-38	.6250	1.0625	.250	.281	21	1/8	.898	.785	.015	.015	3280	1500	1990	1820	.03	2.0
B539DD	-39	.7500	1.1875	.250	.281	24	1/8	1.022	.905	.015	.015	3750	1700	2050	1900	.04	2.0
B540DD	-40	.8750	1.3125	.250	.281	27	1/8	1.139	1.025	.015	.015	4220	1900	2110	1970	.05	3.0
B541DD	-41	1.0625	1.5000	.250	.281	32	1/8	1.337	1.229	.015	.015	5000	2200	2170	2020	.06	4.0
B542DD	-42	1.3125	1.7500	.250	.281	38	1/8	1.578	1.464	.015	.015	5950	2700	2220	2130	.09	4.0
B543DD	-43	1.5625	2.0000	.250	.281	44	1/8	1.820	1.706	.015	.015	6880	3200	2260	2180	.10	5.0
B544DD	-44	1.8125 <sup>(1)</sup>	2.2500 <sup>(2)</sup>	.250	.281	51	1/8	2.109	1.980	.015	.015	7980	3600	2300	2220	.11	6.0
B545DD	-45	2.0625 <sup>(1)</sup>	2.6250 <sup>(2)</sup>	.250	.281	59	1/8	2.413	2.299	.015	.015	9220	4000	2340	2260	.15	7.0
B546DD	-46	2.3125 <sup>(1)</sup>	2.8750 <sup>(2)</sup>	.250	.281	65	1/8	2.656	2.542	.015	.015	10150	4400	2360	2280	.17	8.0

Radial internal clearance: .0008 to .0018

<sup>(1)</sup> Bore (d) tolerance: +.0010 / -.0010

<sup>(2)</sup> O.D. (D) tolerance: +.0000 / -.0015

**MB500DD (AS21428) Precision Series — Qualified to SAE AS7949**

NHBB BASIC P/N	MS21428 DASH NO.	BORE d	O.D. D	RING WIDTH		BALL COMPLEMENT		RING SHOULDER DIAMETER		RING CHAMFER X 45°		LOAD RATINGS (LBS.)				APPROX. WEIGHT	MAX. STARTING TORQUE <sup>^</sup>
				OUTER H	INNER W	NO.	DIA.	OUTER F	INNER E	OUTER A	INNER C	STATIC		DYNAMIC RADIAL* RING ROTATION			
												RADIAL LIMIT	AXIAL LIMIT	INNER	OUTER		
		+0.000 -0.0005	+0.000 -0.0005	+0.00 -0.05	+0.000 -0.025			REF.	REF.	+0.015 -0.000	+0.015 -0.000	RADIAL LIMIT	AXIAL LIMIT			LBS.	OZ.-IN.
MB538DD	-38	.6250	1.0625	.250	.2810	21	1/8	.898	.785	.015	.015	3280	1500	1990	1820	.03	2.0
MB539DD	-39	.7500	1.1875	.250	.2810	24	1/8	1.022	.905	.015	.015	3750	1700	2050	1900	.04	2.0
MB540DD	-40	.8750	1.3125	.250	.2810	27	1/8	1.139	1.025	.015	.015	4220	1900	2110	1970	.05	3.0
MB541DD	-41	1.0625	1.5000	.250	.2810	32	1/8	1.337	1.223	.015	.015	5000	2200	2170	2020	.06	4.0
MB542DD	-42	1.3125	1.7500	.250	.2810	38	1/8	1.578	1.464	.015	.015	5950	2700	2220	2130	.09	4.0
MB543DD	-43	1.5625	2.0000	.250	.2810	44	1/8	1.820	1.706	.015	.015	6880	3200	2260	2180	.10	5.0
MB544DD	-44	1.8125 <sup>(1)</sup>	2.2500 <sup>(2)</sup>	.250	.2810	51	1/8	2.110	1.980	.015	.015	7980	3600	2300	2220	.11	6.0
MB545DD	-45	2.0625 <sup>(1)</sup>	2.6250 <sup>(2)</sup>	.250	.2810	59	1/8	2.413	2.299	.015	.015	9220	4000	2340	2260	.15	7.0
MB546DD	-46	2.3125 <sup>(1)</sup>	2.8750 <sup>(2)</sup>	.250	.2810	65	1/8	2.656	2.542	.015	.015	10150	4400	2360	2280	.17	8.0

Radial internal clearance: .0001 to .0005

<sup>(1)</sup> Bore (d) tolerance: +.0000 / -.0008

<sup>(2)</sup> O.D. (D) tolerance: +.0000 / -.0007

+ Dynamic radial load ratings are for operation up to 250 °F. Reduce load ratings by 20% for 250 to 350 °F operation. Dynamic radial load ratings are based on an average life of 10,000 complete 90° cycles.

<sup>^</sup>Torque limits are for bearings lubricated with MIL-PRF-81322 grease. For bearings lubricated with MIL-PRF-23827, multiply torque limits by a factor of 1.2.

**B500 / MB500 Series**

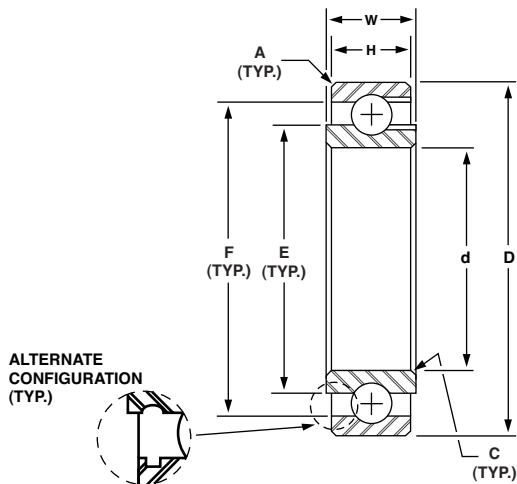

Full ball complement (no retainer)

**Notes:**

1. Rings and balls are manufactured from premium quality AISI 52100 chrome steel.
2. Operating temperature range: -65 to +250 °F.
3. Open type—bearings do not have shields or seals.
4. Bearings are lubricated with a thin film of preservative oil, unless otherwise specified.
5. External surfaces are NOT cadmium plated.
6. Custom sizes, materials, tolerances, radial internal clearances, lubrication, plating, etc., are available upon request.
7. See "Airframe Part Numbering System" on page 5 for correct NHBB nomenclature.
8. All dimensions are in inches, unless otherwise specified.
9. B500/MB500 series are dimensionally interchangeable with B500DD/MB500DD series (applies to bore, O.D., and width).

Refer to the Qualifications and Manufacturing Schedule for a current list of the Precision Division's AS7949 qualifications and manufacturing capabilities.

**B500**

NHBB BASIC P/N	BORE d	O.D. D	RING WIDTH		BALL COMPLEMENT		RING SHOULDER DIAMETER		RING CHAMFER X 45°		LOAD RATINGS (LBS.)				APPROX. WEIGHT LBS.
			OUTER H	INNER W	NO.	DIA.	OUTER F	INNER E	OUTER A	INNER C	STATIC		DYNAMIC RADIAL+ RING ROTATION		
											RADIAL LIMIT	THRUST	INNER	OUTER	
	+0.007 -0.007	+0.000 -0.010	+0.000 -0.005	+0.000 -0.005			REF.	REF.	+0.020 -0.000	+0.020 -0.000	RADIAL LIMIT	AXIAL LIMIT			
B538	.6250	1.0625	.250	.281	21	1/8	.902	.785	.015	.015	3280	1500	1990	1820	.02
B539	.7500	1.1875	.250	.281	24	1/8	1.018	.905	.015	.015	3750	1700	2050	1900	.03
B540	.8750	1.3125	.250	.281	27	1/8	1.139	1.025	.015	.015	4220	1900	2110	1970	.04
B541	1.0625	1.5000	.250	.281	32	1/8	1.338	1.223	.015	.015	5000	2200	2170	2020	.05
B542	1.3125	1.7500	.250	.281	38	1/8	1.590	1.462	.015	.015	5950	2700	2220	2130	.07
B543	1.5625	2.0000	.250	.281	44	1/8	1.831	1.706	.015	.015	6880	3200	2260	2180	.08
B544	1.8125 <sup>(1)</sup>	2.2500 <sup>(2)</sup>	.250	.281	51	1/8	2.109	1.980	.015	.015	7980	3600	2300	2220	.09
B545	2.0625 <sup>(1)</sup>	2.6250 <sup>(2)</sup>	.250	.281	59	1/8	2.424	2.299	.015	.015	9220	4000	2340	2260	.13
B546	2.3125 <sup>(1)</sup>	2.8750 <sup>(2)</sup>	.250	.281	65	1/8	2.668	2.541	.015	.015	10150	4400	2360	2280	.15

Radial internal clearance: .0008 to .0018

<sup>(1)</sup> Bore (d) tolerance: +.0010 / -.0010

<sup>(2)</sup> O.D. (D) tolerance: +.0000 / -.0015

**MB500 Precision Series**

NHBB BASIC P/N	BORE d	O.D. D	RING WIDTH		BALL COMPLEMENT		RING SHOULDER DIAMETER		RING CHAMFER X 45°		LOAD RATINGS (LBS.)				APPROX. WEIGHT LBS.
			OUTER H	INNER W	NO.	DIA.	OUTER F	INNER E	OUTER A	INNER C	STATIC		DYNAMIC RADIAL+ RING ROTATION		
											RADIAL LIMIT	THRUST	INNER	OUTER	
	+0.000 -0.005	+0.000 -0.005	+0.000 -0.005	+0.000 -0.0025			REF.	REF.	+0.020 -0.000	+0.020 -0.000	RADIAL LIMIT	AXIAL LIMIT			
MB538	.6250	1.0625	.250	.2810	21	1/8	.902	.785	.015	.015	3280	1500	1990	1820	.02
MB539	.7500	1.1875	.250	.2810	24	1/8	1.022	.905	.015	.015	3750	1700	2050	1900	.03
MB540	.8750	1.3125	.250	.2810	27	1/8	1.140	1.025	.015	.015	4220	1900	2110	1970	.04
MB541	1.0625	1.5000	.250	.2810	32	1/8	1.338	1.223	.015	.015	5000	2200	2170	2020	.05
MB542	1.3125	1.7500	.250	.2810	38	1/8	1.590	1.462	.015	.015	5950	2700	2220	2130	.07
MB543	1.5625	2.0000	.250	.2810	44	1/8	1.831	1.706	.015	.015	6880	3200	2260	2180	.08
MB544	1.8125 <sup>(1)</sup>	2.2500 <sup>(2)</sup>	.250	.2810	51	1/8	2.109	1.980	.015	.015	7980	3600	2300	2220	.09
MB545	2.0625 <sup>(1)</sup>	2.6250 <sup>(2)</sup>	.250	.2810	59	1/8	2.424	2.299	.015	.015	9220	4000	2340	2260	.13
MB546	2.3125 <sup>(1)</sup>	2.8750 <sup>(2)</sup>	.250	.2810	65	1/8	2.668	2.541	.015	.015	10150	4400	2360	2280	.15

Radial internal clearance: .0001 to .0005

<sup>(1)</sup> Bore (d) tolerance: +.0000 / -.0008

<sup>(2)</sup> O.D. (D) tolerance: +.0000 / -.0007

+Dynamic radial load ratings are for operation up to 250 °F. Reduce load ratings by 20% for 250 to 350 °F operation. Dynamic radial load ratings are based on an average life of 10,000 complete 90° cycles.



**B5500WZZ Series**

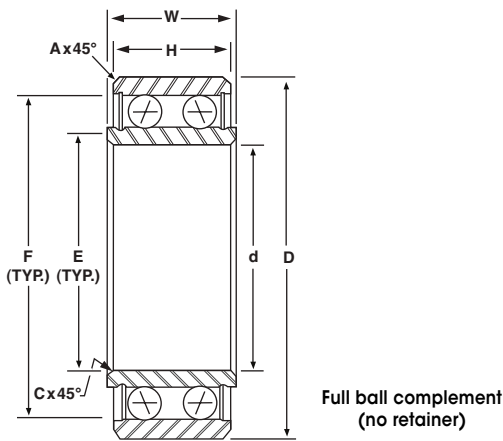

**Notes:**

1. Rings and balls are manufactured from premium quality AISI 52100 chrome steel.
2. Operating temperature range: -65 to +250 °F.
3. All bearings include removable PTFE seals.
4. Bearings are lubricated with MIL-PRF-81322 grease, 80% minimum fill, unless otherwise specified.
5. Contact angles are convergent ( / \ ).
6. External surfaces (except bore) are cadmium plated per AMS-QQ-P-416. All dimensions apply after plating.
7. Custom sizes, materials, tolerances, radial internal clearances, lubrication, plating, etc., are available upon request.
8. See "Airframe Part Numbering System" on page 5 for correct NHBB nomenclature.
9. All dimensions are in inches, unless otherwise specified.

Refer to the Qualifications and Manufacturing Schedule for a current list of the Precision Division's AS7949 qualifications and manufacturing capabilities.

**B5500WZZ**

NHBB BASIC P/N	BORE d	O.D. D	RING WIDTH		BALL COMPLEMENT		RING SHOULDER DIAMETER		RING CHAMFER X 45°		LOAD RATINGS (LBS.)				APPROX. WEIGHT
			OUTER H	INNER W	NO.	DIA.	OUTER F	INNER E	STATIC		DYNAMIC RADIAL* RING ROTATION				
									RADIAL	THRUST	INNER	OUTER			
	+0.0000 -0.0005	+0.0000 -0.0005	+0.000 -0.005	+0.000 -0.005			REF.	REF.	+0.020 -0.000	+0.020 -0.000	RADIAL LIMIT	AXIAL LIMIT			LBS.
B5538WZZ	.6250	1.0625	.500	.562	40	1/8	.883	.759	.015	.015	6250	2060	3040	2790	.04
B5539WZZ	.7500	1.1875	.500	.562	46	1/8	1.002	.878	.015	.015	7190	2370	3130	2910	.06
B5540WZZ	.8750	1.3125	.500	.562	52	1/8	1.121	.997	.015	.015	8120	2680	3210	3010	.08
B5541WZZ	1.0625	1.5000	.500	.562	62	1/8	1.320	1.195	.015	.015	9690	3200	3310	3130	.10
B5542WZZ	1.3125	1.7500	.500	.562	74	1/8	(3)	1.430	.015	.015	11600	3820	3400	3250	.14
B5543WZZ	1.5625	2.0000	.500	.562	86	1/8	1.800	1.675	.015	.015	13400	4430	3470	3330	.16
B5544WZZ	1.8125 (1)	2.2500 (2)	.500	.562	100	1/8	2.075	1.951	.015	.015	15600	5160	3520	3390	.18
B5545WZZ	2.0625 (1)	2.6250 (2)	.500	.562	116	1/8	(3)	2.265	.015	.015	18100	5980	3560	3460	.26
B5546WZZ	2.3125 (1)	2.8750 (2)	.500	.562	128	1/8	(3)	2.505	.015	.015	20000	6600	3680	3490	.30

Radial internal clearance: .0000 to .0010

(1) Bore (d) tolerance: +.0000 / -.0008

(2) O.D. (D) tolerance: +.0000 / -.0007

(3) Contact factory.

+ Dynamic radial load ratings are for operation up to 250 °F. Reduce load ratings by 20% for 250 to 350 °F operation. Dynamic radial load ratings are based on an average life of 10,000 complete 90° cycles.

DW-K, DW- Series (AS27647)

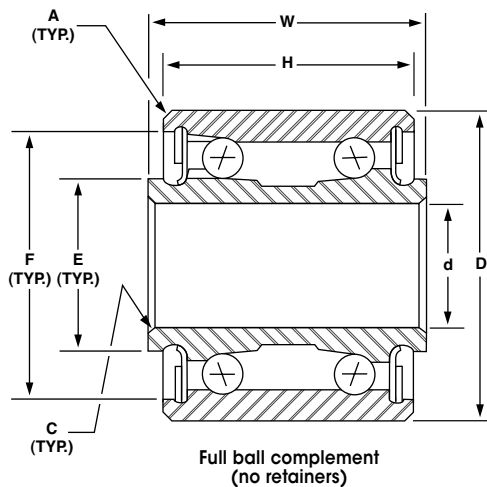
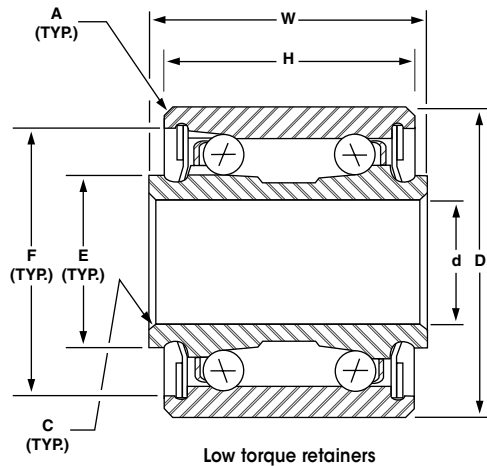

**Notes:**

1. Rings and balls are manufactured from premium quality AISI 52100 chrome steel.
2. Operating temperature range: -65 to +250 °F.
3. All bearings include removable PTFE seals.
4. Bearings are lubricated with MIL-PRF-81322 grease, 80% minimum fill, unless otherwise specified.
5. Contact angles are convergent ( / \ ).
6. External surfaces (except bore) are cadmium plated per AMS-QQ-P-416. All dimensions apply after plating.
7. Custom sizes, materials, tolerances, radial internal clearances, lubrication, plating, etc., are available upon request.
8. See "Airframe Part Numbering System" on page 5 for correct NHBB nomenclature.
9. All dimensions are in inches, unless otherwise specified.

Refer to the Qualifications and Manufacturing Schedule for a current list of the Precision Division's AS7949 qualifications and manufacturing capabilities.

DW-K, DW- (AS27647) — Qualified to SAE AS7949

NHBB BASIC P/N	MS27647 DASH NO.	BORE d	O.D. D	RING WIDTH		BALL COMPLEMENT		RING SHOULDER DIAMETER		RING CHAMFER X 45°		LOAD RATINGS (LBS.)				APPROX. WEIGHT	MAX. STARTING TORQUE <sup>^</sup>
				OUTER H	INNER W	NO.	DIA.	OUTER F	INNER E	STATIC		DYNAMIC RADIAL* RING ROTATION					
										RADIAL LIMIT	THRUST LIMIT	INNER	OUTER				
		+0.000 -0.005	+0.000 -0.005	+0.000 -0.005	+0.000 -0.005			REF.	REF.	+0.015 -0.000	+0.015 -0.000	RADIAL LIMIT	AXIAL LIMIT			LBS.	OZ.-IN.
DW4K2 <sup>(1)</sup>	-4A	.2500	.6250	.500	.562	16	3/32	.523	.344	.016	.005	1400	500	1050	960	.025	1.0
DW4K <sup>(1)</sup>	-4	.2500	.7500	.750	.875	14	9/64	.648	.380	.016	.005	2770	900	2070	1850	.040	1.0
DW4 <sup>(2)</sup>	<sup>(3)</sup>	.2500	.7500	.750	.875	24	1/8	.648	.378	.016	.005	3750	1240	2650	2300	.060	<sup>(4)</sup>
DW5 <sup>(2)</sup>	-5	.3125	.8750	.813	.938	26	9/64	.739	.468	.016	.005	5140	1600	2600	2320	.070	1.5
DW6 <sup>(2)</sup>	-6	.3750	1.0625	1.063	1.188	24	3/16	.916	.568	.016	.005	8440	2600	4220	3740	.120	2.5
DW8 <sup>(2)</sup>	-8	.5000	1.4375	1.375	1.500	22	17/64	1.223	.708	.032	.005	15520	4700	7610	6520	.290	2.5

Radial internal clearance: .0000 to .0010

<sup>(1)</sup> Double row construction—low torque retainers

<sup>(2)</sup> Double row construction—full ball complement (no retainers)

<sup>(3)</sup> DW4 equivalent not specified.

<sup>(4)</sup> Torque limit not defined.

+ Dynamic radial load ratings are for operation up to 250 °F. Reduce load ratings by 20% for 250 to 350 °F operation. Dynamic radial load ratings are based on an average life of 10,000 complete 90° cycles.

<sup>^</sup> Torque limits are for bearings lubricated with MIL-PRF-81322 grease. For bearings lubricated with MIL-PRF-23827, multiply torque limits by a factor of 1.2.



**GDW-K, GDW- Series (AS27647)**

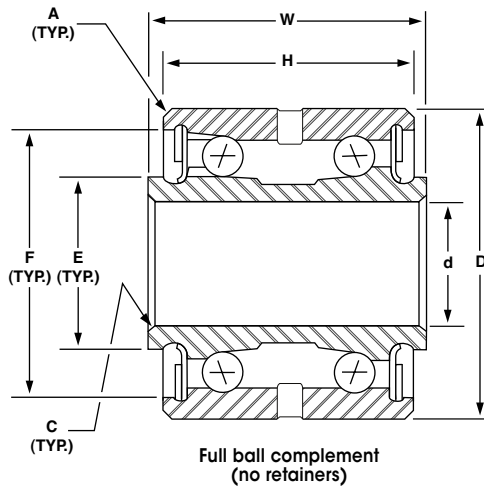
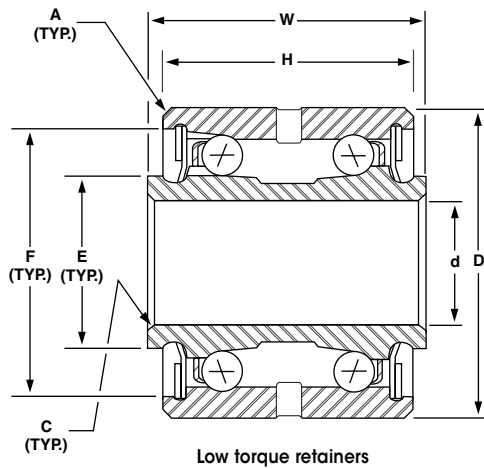

**Notes:**

1. Rings and balls are manufactured from premium quality AISI 52100 chrome steel.
2. Operating temperature range: -65 to +250 °F.
3. All bearings include removable PTFE seals.
4. Bearings are lubricated with MIL-PRF-81322 grease, 80% minimum fill, unless otherwise specified.
5. Contact angles are convergent ( / \ ).
6. Special feature: relubrication groove with grease holes.
7. External surfaces (except bore) are cadmium plated per AMS-QQ-P-416. All dimensions apply after plating.
8. Custom sizes, materials, tolerances, radial internal clearances, lubrication, plating, etc., are available upon request.
9. See "Airframe Part Numbering System" on page 5 for correct NHBB nomenclature.
10. All dimensions are in inches, unless otherwise specified.

Refer to the Qualifications and Manufacturing Schedule for a current list of the Precision Division's AS7949 qualifications and manufacturing capabilities.

**GDW-K, GDW- (AS27647) — Qualified to SAE AS7949**

NHBB BASIC P/N	MS27647-G DASH NO.	BORE d	O.D. D	RING WIDTH		BALL COMPLEMENT		RING SHOULDER DIAMETER		RING CHAMFER X 45°		LOAD RATINGS (LBS.)				APPROX. WEIGHT	MAX. STARTING TORQUE <sup>^</sup>
				OUTER H	INNER W	NO.	DIA.	OUTER F	INNER E	OUTER A	INNER C	STATIC		DYNAMIC RADIAL + RING ROTATION			
												RADIAL LIMIT	THRUST LIMIT	INNER	OUTER		
		+0.000 -0.005	+0.000 -0.005	+0.000 -0.005	+0.000 -0.005			REF.	REF.	+0.015 -0.000	+0.015 -0.000	RADIAL LIMIT	THRUST LIMIT			LBS.	OZ.-IN.
GDW4K2 <sup>(1)</sup>	-4AG	.2500	.6250	.500	.562	16	3/32	.523	.344	.016	.005	1400	500	1050	960	.025	1.0
GDW4K <sup>(1)</sup>	-4G	.2500	.7500	.750	.875	14	9/64	.648	.380	.016	.005	2770	900	2070	1850	.040	1.0
GDW4 <sup>(2)</sup>	(3)	.2500	.7500	.750	.875	24	1/8	.648	.378	.016	.005	3750	1240	2650	2300	.060	(4)
GDW5 <sup>(2)</sup>	-5G	.3125	.8750	.813	.938	26	9/64	.739	.468	.016	.005	5140	1600	2600	2320	.070	1.5
GDW6 <sup>(2)</sup>	-6G	.3750	1.0625	1.063	1.188	24	3/16	.916	.572	.016	.005	8440	2600	4220	3740	.120	2.5
GDW8 <sup>(2)</sup>	-8G	.5000	1.4375	1.375	1.500	22	17/64	1.223	.708	.032	.005	15520	4700	7610	6520	.290	2.5

Radial internal clearance: .0000 to .0010

- (1) Double row construction—low torque retainers
- (2) Double row construction—full ball complement (no retainers)
- (3) GDW4 equivalent not specified.
- (4) Torque limit not defined.

+ Dynamic radial load ratings are for operation up to 250 °F. Reduce load ratings by 20% for 250 to 350 °F operation. Dynamic radial load ratings are based on an average life of 10,000 complete 90° cycles.

<sup>^</sup> Torque limits are for bearings lubricated with MIL-PRF-81322 grease. For bearings lubricated with MIL-PRF-23827, multiply torque limits by a factor of 1.2.



MDW-K, MDW- Series

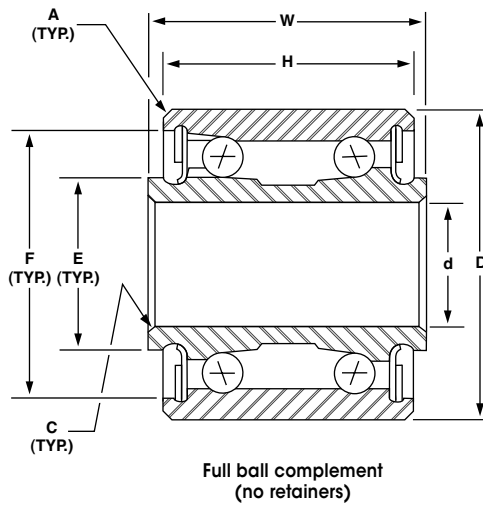
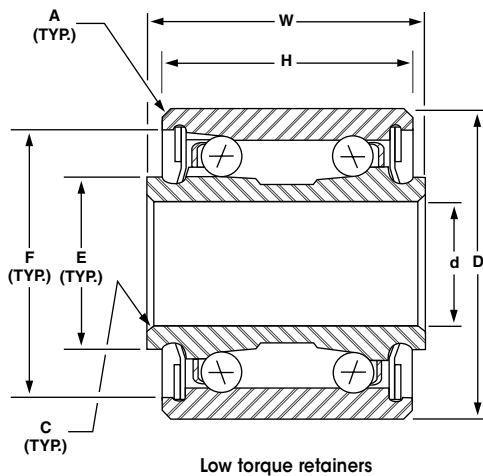

**Notes:**

1. Rings and balls are manufactured from premium quality AISI 52100 chrome steel.
2. Operating temperature range: -65 to +250 °F.
3. All bearings include removable PTFE seals.
4. Bearings are lubricated with MIL-PRF-81322 grease, 80% minimum fill, unless otherwise specified.
5. Contact angles are convergent ( / \ ).
6. External surfaces (except bore) are cadmium plated per AMS-QQ-P-416. All dimensions apply after plating.
7. Custom sizes, materials, tolerances, radial internal clearances, lubrication, plating, etc., are available upon request.
8. See "Airframe Part Numbering System" on page 5 for correct NHBB nomenclature.
9. All dimensions are in inches, unless otherwise specified.

Refer to the *Qualifications and Manufacturing Schedule* for a current list of the Precision Division's AS7949 qualifications and manufacturing capabilities.

MDW-K, MDW-

NHBB BASIC P/N	BORE d	O.D. D	RING WIDTH		BALL COMPLEMENT		RING SHOULDER DIAMETER		RING CHAMFER X 45°		LOAD RATINGS (LBS.)				APPROX. WEIGHT	MAX. STARTING TORQUE <sup>^</sup>
			OUTER H	INNER W	NO.	DIA.	OUTER F	INNER E	STATIC		DYNAMIC RADIAL* RING ROTATION					
									RADIAL	THRUST	INNER	OUTER				
	+0.000 -0.003	+0.000 -0.004	+0.00 -0.05	+0.000 -0.025			REF.	REF.	+0.015 -0.000	+0.015 -0.000	RADIAL LIMIT	AXIAL LIMIT			LBS.	OZ.-IN.
MDW4K2 <sup>(1)</sup>	.2500	.6250	.500	.5620	16	3/32	.523	.344	.016	.005	1400	500	1050	960	.025	1.0
MDW4K <sup>(1)</sup>	.2500	.7500	.750	.8750	14	9/64	.648	.380	.016	.005	2770	900	2070	1850	.040	1.0
MDW4 <sup>(2)</sup>	.2500	.7500	.750	.8750	24	1/8	.648	.378	.016	.005	3750	1240	2650	2300	.060	<sup>(3)</sup>
MDW5 <sup>(2)</sup>	.3125	.8750	.813	.9380	26	9/64	.739	.468	.016	.005	5140	1600	2600	2320	.070	1.5
MDW6 <sup>(2)</sup>	.3750	1.0625	1.063	1.1880	24	3/16	.916	.572	.016	.005	8440	2600	4220	3740	.120	2.5
MDW8 <sup>(2)</sup>	.5000	1.4375	1.375	1.5000	22	17/64	1.223	.708	.032	.005	15520	4700	7610	6520	.290	2.5

Radial internal clearance: .0002 to .0005

<sup>(1)</sup> Double row construction—low torque retainers

<sup>(2)</sup> Double row construction—full ball complement (no retainers)

<sup>(3)</sup> Torque limit not defined.

\* Dynamic radial load ratings are for operation up to 250 °F. Reduce load ratings by 20% for 250 to 350 °F operation. Dynamic radial load ratings are based on an average life of 10,000 complete 90° cycles.

<sup>^</sup> Torque limits are for bearings lubricated with MIL-PRF-81322 grease. For bearings lubricated with MIL-PRF-23827, multiply torque limits by a factor of 1.2.



SSW-AK Series (AS27649)

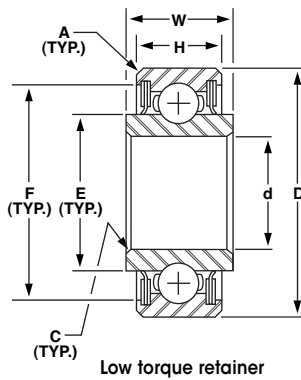

Notes:

1. Rings and balls are manufactured from premium quality AISI 440C stainless steel.
2. Operating temperature range: -65 to +250 °F.
3. All bearings include removable PTFE seals.
4. Bearings are lubricated with MIL-PRF-81322 grease, 80% minimum fill, unless otherwise specified.
5. Custom sizes, materials, tolerances, radial internal clearances, lubrication, plating, etc., are available upon request.
6. See "Airframe Part Numbering System" on page 5 for correct NHBB nomenclature.
7. All dimensions are in inches, unless otherwise specified.

Refer to the Qualifications and Manufacturing Schedule for a current list of the Precision Division's AS7949 qualifications and manufacturing capabilities.

SSW-AK (AS27649) — Qualified to SAE AS7949

NHBB BASIC P/N	MS27649 DASH NO.	BORE d	O.D. D	RING WIDTH		BALL COMPLEMENT		RING SHOULDER DIAMETER		RING CHAMFER X 45°		LOAD RATINGS (LBS.)				APPROX. WEIGHT	MAX. STARTING TORQUE <sup>^</sup>
				OUTER H	INNER W	NO.	DIA.	OUTER F	INNER E	OUTER A	INNER C	STATIC		DYNAMIC RADIAL* RING ROTATION			
												RADIAL LIMIT	THRUST	INNER	OUTER		
		+0.0000 -0.0005	+0.0000 -0.0005	+0.000 -0.005	+0.0000 -0.0025			REF.	REF.	+0.015 -0.000	+0.015 -0.000					LBS.	OZ.-IN.
SSW3AK	-3	.1900	.6250	.312	.4060	6	1/8	.519	.295	.016	.005	450	210	440	440	.018	1.0
SSW4AK	-4	.2500	.7500	.312	.4380	6	9/64	.643	.402	.016	.005	525	250	510	510	.028	1.5
SSW5AK	-5	.3125	.8125	.344	.4690	7	5/32	.721	.463	.016	.015	820	380	800	800	.033	1.5
SSW6AK	-6	.3750	.8750	.344	.4690	7	5/32	.768	.520	.016	.015	820	380	800	800	.034	2.0
SSW8AK	-8	.5000	1.1250	.438	.5620	8	3/16	.968	.669	.016	.015	1350	630	1310	1310	.075	2.5
SSW10AK	-10	.6250	1.3750	.469	.5940	8	7/32	1.242	.848	.032	.015	1840	860	1790	1790	.119	3.0
SSW12AK	-12	.7500	1.6250	.531	.6560	8	1/4	1.370	1.018	.032	.015	2400	1120	2340	2340	.189	3.0
SSW16AK	-16	1.0000	2.0000	.562	.6880	10	1/4	1.672	1.334	.032	.015	3000	1400	2920	2920	.296	4.0
SSW20AK	-20	1.2500	2.2500	.562	.6880	12	1/4	1.953	1.615	.032	.015	3600	1680	3500	3270	.355	5.0

Radial internal clearance: .0003 to .0009

+ Dynamic radial load ratings are for operation up to 250 °F. Reduce load ratings by 20% for 250 to 350 °F operation. Dynamic radial load ratings are based on an average life of 10,000 complete 90° cycles.

<sup>^</sup> Torque limits are for bearings lubricated with MIL-PRF-81322 grease. For bearings lubricated with MIL-PRF-23827, multiply torque limits by a factor of 1.2.



K- Series

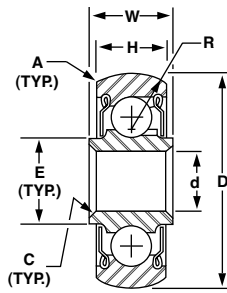

**K3L2**

Full ball complement (no retainer)

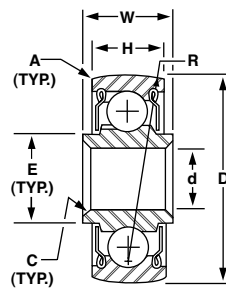

**K3L3, K3LR48**

Full ball complement (no retainer)

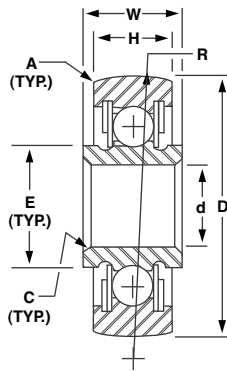

**KP3AR11-2 through KP4R25-2**

Full ball complement (no retainer)

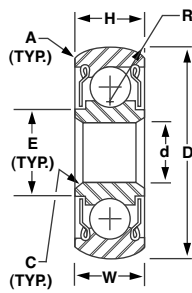

**K8AR4**

Full ball complement (no retainer)

**Notes:**

1. Rings and balls are manufactured from premium quality AISI 52100 chrome steel.
2. Operating temperature range: -65 to +250 °F.
3. Shield or seal type is specified below—see footnotes (1) and (2).
4. Bearings are lubricated with MIL-PRF-81322 grease, 80% minimum fill, unless otherwise specified.
5. External surfaces (except bore) are cadmium plated per AMS-QQ-P-416. All dimensions apply after plating.
6. Custom sizes, materials, tolerances, radial internal clearances, lubrication, plating, etc., are available upon request.
7. See "Airframe Part Numbering System" on page 5 for correct NHBB nomenclature.
8. All dimensions are in inches, unless otherwise specified.

Refer to the Qualifications and Manufacturing Schedule for a current list of the Precision Division's AS7949 qualifications and manufacturing capabilities.

**K-**

NHBB BASIC P/N	BORE d	O.D. D	O.D. RADIUS R		RING WIDTH		BALL COMPLEMENT		INNER RING SHOULDER DIAMETER E	RING CHAMFER X 45°		MAX. SAFE WORKING LOAD ^	APPROX. WEIGHT
			MAX.	MIN.	OUTER H	INNER W	NO.	DIA.		OUTER A	INNER C		
	+0.000 -0.005	+0.000 -0.002			+0.000 -0.005	+0.000 -0.005			REF.	REF.	+0.015 -0.000	RADIAL LBS.	LBS.
K3L2 <sup>(1)</sup>	.1900	.687	.187	.182	.203	.245	10	1/8	.277	.020 <sup>(5)</sup>	.005	200	.01
K3L3 <sup>(1)</sup>	.1900	.635 <sup>(3)</sup>	.550	.500	.203	.245	10	1/8	.277	.020 <sup>(5)</sup>	.005	200	.01
K3LR48 <sup>(1)</sup>	.1900	.687	3.015	2.985	.203	.245	10	1/8	.277	.020 <sup>(5)</sup>	.005	200	.02
KP3AR11-2 <sup>(2)</sup>	.1900	.718 <sup>(4)</sup>	.359	.358	.265	.297	10	1/8	.297	.015 <sup>(5)</sup>	.005	300	.02
KP4AR13 <sup>(2)</sup>	.2500	.800	.812	.802	.219	.281	12	1/8	.380	.015	.005	400	.02
KP4AR48 <sup>(2)</sup>	.2500	.800	3.015	2.985	.219	.281	12	1/8	.375	.015	.005	400	.02
KP4R16 <sup>(2)</sup>	.2500	.901	1.000	.990	.335	.484	11	5/32	.387	.015	.005	400	.04
KP4R16-2 <sup>(2)</sup>	.2500	1.000	1.000	.990	.335	.390	11	5/32	.390	.015	.005	500	.06
KP4R16-3 <sup>(2)</sup>	.2500	.901	1.000	.990	.335	.390	11	5/32	.390	.015	.005	400	.04
KP4R21-2SD1000 <sup>(2)</sup>	.2500	1.312	1.312	1.302	.281	.376	13	3/16	.582	.015	.005	500	.10
KP4R25-2SD1000 <sup>(2)</sup>	.2500	1.656	1.656	1.654	.315	.376	13	3/16	.582	.015	.005	500	.16
K8AR4 <sup>(1)</sup>	.5000	1.250	.252	.248	.375	.344	16	5/32	.610	.015	.016	500	.05

Radial internal clearance: .0004 to .0010

<sup>(1)</sup> Nonremovable stainless steel shields. Also available with PTFE seals bonded to nonremovable stainless steel shields. Consult factory for availability.

<sup>(2)</sup> Removable PTFE seals

<sup>(3)</sup> O.D. (D) tolerance: +.000 / -.003

<sup>(4)</sup> Spherical diameter

<sup>(5)</sup> Radius

^ Maximum safe working load based on 100,000 feet peripheral travel life.



D- Series

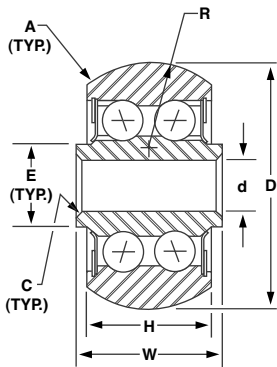

Spherical O.D.  
Full ball complement  
(no retainers)

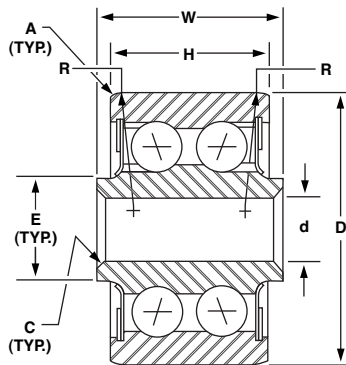

Cylindrical O.D. with blended corner radius  
Full ball complement  
(no retainers)

Notes:

1. Rings and balls are manufactured from premium quality AISI 52100 chrome steel.
2. Operating temperature range: -65 to +250 °F.
3. All bearings include removable PTFE seals.
4. Contact angles are divergent (° \ /).
5. Bearings are lubricated with MIL-PRF-81322 grease, 80% minimum fill, unless otherwise specified.
6. External surfaces (except bore) are cadmium plated per AMS-QQ-P-416. All dimensions apply after plating.
7. Custom sizes, materials, tolerances, radial internal clearances, lubrication, plating, etc., are available upon request.
8. See "Airframe Part Numbering System" on page 5 for correct NHBB nomenclature.
9. All dimensions are in inches, unless otherwise specified.

Refer to the Qualifications and Manufacturing Schedule for a current list of the Precision Division's AS7949 qualifications and manufacturing capabilities.

D-

NHBB BASIC P/N	BORE d	O.D. D	O.D. RADIUS R		RING WIDTH		BALL COMPLEMENT		INNER RING SHOULDER DIAMETER E	RING CHAMFER X 45°		MAX. SAFE WORKING LOAD ^	APPROX. WEIGHT
					OUTER H	INNER W	NO.	DIA.		OUTER A	INNER C		
	+ .0000 - .0005	+ .000 - .005	MAX.	MIN.	+ .000 - .005	+ .000 - .005			REF.	REF.	+ .015 - .000	RADIAL LBS.	LBS.
DPP5R10-2 <sup>(2)</sup>	.3125	1.400 <sup>(3)</sup>	.635	.615	.687	.745	22	15/64	.524	.039	.015	1800	.19
D7R6-2 <sup>(1)</sup>	.4375	1.250 <sup>(3)</sup>	.375	.365	.600	.625	28	5/32	.545	.050	.005	1000	.12
D7R6-3 <sup>(1)</sup>	.4375	1.625 <sup>(3)</sup>	.375	.365	.600	.625	26	3/16	.566	.005	.005	2000	.16
D7R48-3 <sup>(1)</sup>	.4375	1.625	3.015	3.005	.600	.625	26	3/16	.566	.050	.005	2000	.18
DP8A3 <sup>(2)</sup>	.5000	1.225	.515	.485	.527	.625	32	5/32	.610	.040	.005	1000	.11
DP8A4 <sup>(2)</sup>	.5000	1.500 <sup>(4)</sup>	1.010	.990	.527	.625	32	5/32	.610	.030	.005	1800	.14

Radial internal clearance: .0001 to .0010

<sup>(1)</sup> Spherical O.D.

<sup>(2)</sup> Cylindrical O.D. with blended corner radius

<sup>(3)</sup> O.D. (D) tolerance: +.000 / -.010

<sup>(4)</sup> O.D. (D) tolerance: +.000 / -.001

^ Maximum safe working load based on 100,000 feet peripheral travel life.

KP-AK, KP-K, W-AK, P-K, PD-K, P- Series (AS21443)

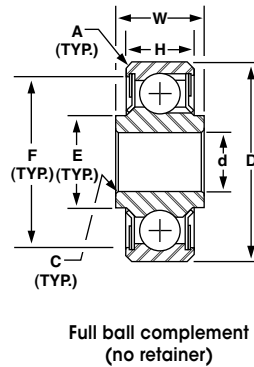
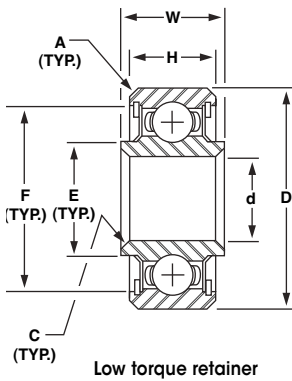
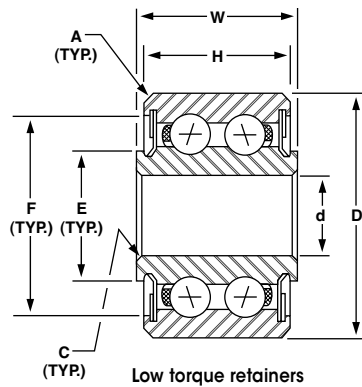

Notes:

1. Rings and balls are manufactured from premium quality AISI 52100 chrome steel.
2. Operating temperature range: -65 to +250 °F.
3. All bearings include removable PTFE seals.
4. Bearings are lubricated with MIL-PRF-81322 grease, 80% minimum fill, unless otherwise specified.
5. External surfaces (except bore) are cadmium plated per AMS-QQ-P-416. All dimensions apply after plating.
6. Custom sizes, materials, tolerances, radial internal clearances, lubrication, plating, etc., are available upon request.
7. See "Airframe Part Numbering System" on page 5 for correct NHBB nomenclature.
8. All dimensions are in inches, unless otherwise specified.

Refer to the Qualifications and Manufacturing Schedule for a current list of the Precision Division's AS7949 qualifications and manufacturing capabilities.

KP-AK, KP-K, W-AK, P-K, PD-K, P- (AS21443) — Qualified to SAE AS7949

NHBB BASIC P/N	MS21443 DASH NO.	BORE d	O.D. D	RING WIDTH		BALL COMPLEMENT		RING SHOULDER DIAMETER		RING CHAMFER X 45°		LOAD RATINGS (LBS.)				APPROX. WEIGHT
				OUTER H	INNER W	NO.	DIA.	OUTER F	INNER E	STATIC		DYNAMIC RADIAL+ RING ROTATION				
										RADIAL	THRUST	INNER	OUTER			
		+0.000 -0.005	+0.000 -0.005	+0.000 -0.005	+0.000 -0.005			REF.	REF.	+0.015 -0.000	+0.015 -0.000	RADIAL LIMIT	AXIAL LIMIT			LBS.
KP3AK <sup>(1)</sup>	-3A	.1900	.6250	.234	.297	8	3/32	.522	.297	.016	.005	705	385	705	705	.01
KP3AK2 <sup>(1)</sup>	(4)	.1900	.6250	.234	.625	8	3/32	.522	.297	.016	.005	705	385	705	705	.02
KP3K <sup>(1)</sup>	-3B	.1900	.7774	.270	.297	7	1/8	.623	.328	.024	.005	1090	600	1090	1090	.02
W4AK <sup>(1)</sup>	-4A	.2500	.7500	.312	.438	6	9/64	.646	.400	.016	.005	1090	600	1090	1090	.03
P4K <sup>(1)</sup>	-4B	.2500	.8750	.375	.438	7	5/32	.725	.433	.022	.005	1710	800	1710	1710	.04
KP4K <sup>(1)</sup>	-4C	.2500	.9014	.335	.484	7	5/32	.735	.405	.034	.005	1710	800	1710	1710	.04
P5K <sup>(1)</sup>	-5A	.3125	.8750	.375	.625	7	5/32	.725	.455	.022	.005	1710	800	1710	1710	.04
PD5K <sup>(2)</sup>	-5B	.3125	.9375	.563	.625	14	5/32	.774	.475	.022	.005	3420	1030	3250	2800	.07
P8 <sup>(3)</sup>	-8	.5000	1.6875	.563	.750	10	11/32	1.457	.768	.032	.005	11800	5200	9320	7730	.24
P10K <sup>(1)(5)</sup>	-10	.6250	1.1875	.375	.438	11	5/32	1.048	.749	.022	.005	2440	1100	2420	2180	.06

Radial internal clearance: .0004 to .0010

- (1) Single row construction—low torque retainer
- (2) Double row construction—low torque retainers
- (3) Single row construction—full ball complement (no retainer)
- (4) KP3AK2 equivalent not defined.
- (5) Riveted cage

+ Dynamic radial load ratings are for operation up to 250 °F. Reduce load ratings by 20% for 250 to 350 °F operation. Dynamic radial load ratings are based on an average life of 10,000 complete 90° cycles.



G-, GD- Series

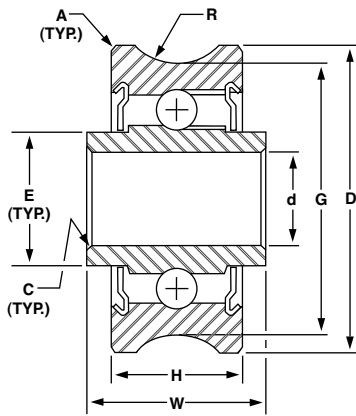

Full ball complement (no retainers)

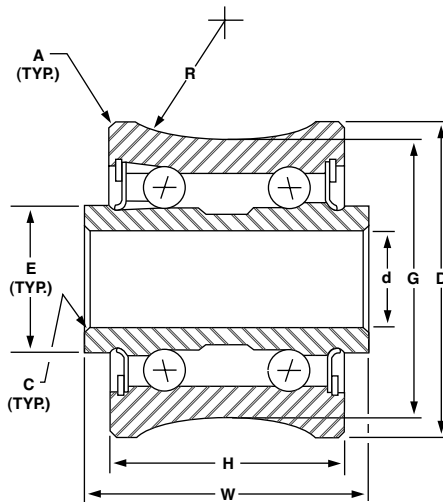

Full ball complement (no retainers)

Notes:

1. Rings and balls are manufactured from premium quality AISI 52100 chrome steel.
2. Operating temperature range: -65 to +250 °F.
3. Shield or seal type is specified below—see footnotes (3) and (4).
4. Bearings are lubricated with MIL-PRF-81322 grease, 80% minimum fill, unless otherwise specified.
5. External surfaces (except bore) are cadmium plated per AMS-QQ-P-416. All dimensions apply after plating.
6. Custom sizes, materials, tolerances, radial internal clearances, lubrication, plating, etc., are available upon request.
7. See "Airframe Part Numbering System" on page 5 for correct NHBB nomenclature.
8. All dimensions are in inches, unless otherwise specified.

Refer to the Qualifications and Manufacturing Schedule for a current list of the Precision Division's AS7949 qualifications and manufacturing capabilities.

G-, GD-

NHBB BASIC P/N	BORE d	O.D. D	RING WIDTH		BALL COMPLEMENT		INNER RING SHOULDER DIAMETER E	RING CHAMFER X 45°		GROOVE DIAMETER G	GROOVE RADIUS R	MAX. SAFE WORKING LOAD ^	APPROX. WEIGHT
			OUTER H	INNER W	NO.	DIA.		OUTER A	INNER C				
	+0.000 -0.005	+0.000 -0.010	+0.000 -0.005	+0.0000 -0.0050			REF.	+0.015 -0.000	+0.015 -0.000	+0.000 -0.001	REF.	RADIAL LBS.	LBS.
G4Y17 <sup>(1)(3)</sup>	.2500	1.037	.563	.6250	12	5/32	.410	.005	.032	.906 <sup>(5)</sup>	.541	400	.08
GD5M20 <sup>(2)(4)</sup>	.3125	1.015	.812	.9375	26	9/64	.472	.005	.005	.901	.630	600	.11
GD5M28 <sup>(2)(4)</sup>	.3125	1.015	.812	.9375	26	9/64	.472	.005	.005	.901	.895	600	.10

Radial internal clearance: .0001 to .0010

- (1) Single row construction—full ball complement (no retainer)
- (2) Double row construction—full ball complement (no retainers)
- (3) Nonremovable stainless steel shields
- (4) Removable PTFE seals
- (5) Groove diameter (G) tolerance: +.000 / -.002

^ Maximum safe working load based on 100,000 feet peripheral travel life.



# Corporate Overview



### **Committed to Excellence**

We continue to build strong alliances within the aerospace, defense, dental, medical, and high technology markets, working across the enterprise to provide business solutions that keep pace with our customers' technological advances.

The precision tolerances required by the customers we support necessitate a complete commitment to quality. At NHBB, that commitment is apparent in everything we do, from an investment in advanced capabilities, to real-time quality control, to continuous improvement in both processes and people. Our commitment to manufacturing excellence is seen time and again in our high level of service and product quality.

### **Applications Engineering**

Knowing how to leverage knowledge, industry experience, emerging technology, and industry trends is the true differentiator when it comes to customized bearing assemblies. At NHBB, we offer complete bearing engineering support for every phase of a product's life cycle, and we do this with a passion for serving as a valued technical resource to our customers.

### **Manufacturing**

Investing in the most advanced technologies available gives NHBB a significant advantage in precision manufacturing. We're able to guarantee the close tolerances necessary in life-critical and high speed applications, as well as address manufacturing challenges in-house through new tools, precision gages, and state-of-the-art production processes.

### **Care for the Environment**

At NHBB, our stringent environmental policy emphasizes pollution prevention, regulatory compliance, and continuous improvement aimed at reducing the impact of every phase of the manufacturing process. Our objectives also include the promotion of environmental awareness among employees and within our communities.

## Precision Division, Chatsworth, CA

Our Precision Division is an industry leader in applying volume production methods to the manufacture of sophisticated, non-standard, ultra-precision miniature and instrument bearing designs. Our strong product testing and development program enables us to provide our customers with unique and cost-efficient solutions without sacrificing performance and precision, especially in high-speed and low-torque applications.

### PRODUCTS

- Ultra-precision miniature & instrument ball bearings:
  - Inch and metric
  - Hybrid ceramic
  - Torque tube/thin section
  - Duplex/super duplex
  - Modified dimensions
  - Machined cages
- Middle size bearings (up to 2.5" O.D.)
- Airframe control bearings
- Mechanical assemblies

### QUALITY CERTIFICATIONS

- ISO 9001:2008
- AS9100, Rev C

### NADCAP

- AC7102 – Heat-treating

### ENVIRONMENTAL MANAGEMENT CERTIFICATION

- ISO 14001:2004



## HiTech Division, Peterborough, NH

HiTech specializes in customized and sophisticated bearing assemblies, cylindrical roller bearings, and large-diameter precision ball bearings. We have the ability to provide unique, custom bearing solutions to complex and demanding challenges, including high loads, extreme speeds, limited space, simplified assembly, and highly-efficient lubrication distribution, to name a few.

### PRODUCTS

- Complex ball and roller bearings
- Bearing sizes through 300 mm O.D.
- Cylindrical roller bearings
- Ball bearings:
  - Angular contact
  - Gothic arch
  - Duplex/super duplex
  - Torque tube
  - Thin section

### QUALITY CERTIFICATIONS

- ISO 9001:2008
- AS9100, Rev C
- Boeing D6-82479

### NADCAP

- AC7102 – Heat-treating – including carburizing
- AC7108 – Chemical processing – including passivation
- AC7114 – Nondestructive testing

### ENVIRONMENTAL MANAGEMENT CERTIFICATION

- ISO 14001:2004





## Astro Division, Laconia, NH

Astro designs and manufactures highly specialized custom bearings, next-up assemblies, and machined parts requiring significant engineering expertise and specialty materials. Our stringent process controls and advanced planning system enable us to satisfy unique production requirements and provide improved delivery scheduling as part of our continuous improvement culture and commitment to customer satisfaction.

### PRODUCTS

- Rod ends
- Sphericals
- Link assemblies
- Bushings
- Loader slot bearings
- Custom-lined parts
- Bearings up to 22" O.D.
- Next-up assemblies & machined parts



### NMB, KARUIZAWA, JAPAN\*

- Rod ends
- Sphericals
- Spherical roller bearings
- Self-aligning roller bearings
- Next-up assemblies & machined parts



### QUALITY CERTIFICATIONS

- ISO 9001:2008
- AS9100, Rev C
- Boeing D6-82479
- FAA FAR 21.303

### NADCAP

- AC7102 – Heat-treating
- AC7108 – Chemical processing
- AC7114 – Nondestructive testing
- AC7118 – Composites/bonding



### ENVIRONMENTAL MANAGEMENT CERTIFICATION

- ISO 14001:2004

\*Astro is the North American sales representative for products manufactured by NMB's facility in Karuizawa, Japan, giving customers access to a global supply of high quality commercial aerospace parts.

**myonic USA, Chatsworth, CA**

myonic is a German manufacturer of precision miniature ball bearings acquired in 2009 by our parent company, Minebea Co., Ltd. and represented in the US solely by myonic USA. Our manufacturing facility specializes in the design and manufacture of highly-engineered mechanical subassemblies and miniature ball bearings for the dental, medical, aviation and aerospace industries.



**PRODUCTS**

- Ultra precision miniature ball bearings
  - Deep groove radial
  - Angular contact
  - Full line of metric
- Thrust bearings
- X-ray tube bearings
- Aircraft instrument bearings
- Dental bearings
  - Integral shaft
  - Complete turbine assemblies
  - Laser welded shields
  - Hybrid ceramic
  - Spindles/auto chucks
- Shims and washers
- Customized bearing systems
- Contract manufactured products

**QUALITY CERTIFICATION**

- ISO 9001:2008

**ENVIRONMENTAL MANAGEMENT CERTIFICATION**

- ISO 14001:2004





**Minebea Co., Ltd.**

New Hampshire Ball Bearings and myonic are an integral part of an international business. Our parent company, Minebea Co., Ltd., is the world's leading specialized manufacturer of miniature ball bearings and high precision components for the telecommunications, aerospace, automotive, and electrical appliance industries.

The Minebea Group is comprised of 43 subsidiaries in 17 countries, and employs over 50,000 people. In addition to its worldwide manufacturing capabilities, Minebea's vision is to lead the competition through manufacturing and technological excellence.







New Hampshire Ball Bearings, Inc.

— *A Minebea Company* —

**Precision Division and  
Corporate Headquarters**

9700 Independence Avenue  
Chatsworth, CA 91311

tel: 818.993.4100 fax: 818.407.5020

**HiTech Division**

175 Jaffrey Road

Peterborough, NH 03458

tel: 603.924.4100 fax: 603.924.9302

**Other NHBB Divisions**

**Astro Division**

155 Lexington Drive

Laconia, NH 03246

tel: 603.524.0004 fax: 603.524.9025

**myonic USA**

9700 Independence Avenue

Chatsworth, CA 91311

tel: 818.701.4833 fax: 818.407.5020

**NHBB Europe**

Siemensstrasse 30

63225 Langen

Germany

tel: (49) 6103.913.341 fax: (49) 6103.913.342

**[nhbb.com](http://nhbb.com)**